



xPico™
User Guide

Vertrieb durch
Distribution by

HY-LINE®
COMPUTER COMPONENTS

Inselkammerstr. 10
D-82008 Unterhaching
Tel.: +49 89 614 503 40
www.hy-line.de

Part Number 900-618
Revision B January 2013

Copyright and Trademark

© 2013 Lantronix. All rights reserved. No part of the contents of this book may be transmitted or reproduced in any form or by any means without the written permission of Lantronix.

DeviceLinx®, xPico™ and DeviceInstaller™ are trademarks of Lantronix.

Ethernet is a trademark of XEROX Corporation. UNIX is a registered trademark of The Open Group. Windows is a trademark of Microsoft Corp.

Warranty

For details on the Lantronix warranty policy, please go to our Web site at www.lantronix.com/support/warranty.

Contacts

Lantronix Corporate Headquarters

167 Technology Drive
Irvine, CA 92618, USA

Toll Free: 800-526-8766

Phone: 949-453-3995

Fax: 949-450-7249

Technical Support

Online: www.lantronix.com/support

Sales Offices

For a current list of our domestic and international sales offices, go to the Lantronix web site at www.lantronix.com/about/contact

Disclaimer

Operation of this equipment in a residential area is likely to cause interference, in which case the user, at his or her own expense, will be required to take whatever measures may be required to correct the interference.

Note: *This product has been designed to comply with the limits for a Class B digital device pursuant to Part 15 of FCC Rules. These limits are designed to provide reasonable protection against harmful interference in a residential installation. This equipment generates, uses, and can radiate radio frequency energy, and if not installed and used in accordance with this guide, may cause harmful interference to radio communications.*

Changes or modifications to this device not explicitly approved by Lantronix will void the user's authority to operate this device.

Note: *With the purchase of xPico, the OEM agrees to an OEM firmware license agreement that grants the OEM a non-exclusive, royalty-free firmware license to use and distribute the binary firmware image provided, only to the extent necessary to use the xPico hardware. For further details, please see the xPico OEM firmware license agreement.*

Revision History

Date	Rev.	Comments
April 2012	A	Initial release for firmware version 6.8.0.0.
January 2013	B	Updated for firmware version 6.8.0.3.

For the latest revision of this product document, please check our online documentation at www.lantronix.com/support/documentation.

Table of Contents

Copyright and Trademark.....	2
Warranty.....	2
Contacts.....	2
Disclaimer.....	3
Revision History.....	3
List of Tables.....	8
List of Figures.....	8
1. Using This Guide	9
Purpose and Audience.....	9
Chapter Summary.....	9
Additional Documentation.....	10
2. Introduction	11
Capabilities.....	11
Applications.....	11
Protocol Support.....	12
Configuration Methods.....	12
Addresses and Port Numbers.....	12
Hardware Address.....	12
IP Address.....	13
Port Numbers.....	13
Product Information Label.....	13
3. Using DeviceInstaller	14
Installing DeviceInstaller.....	14
Assigning an IP Address.....	14
Accessing the xPico Using DeviceInstaller.....	15
Viewing the Current Configuration.....	15
4. Configuration Using Web Manager	18
Accessing Web-Manager Using DeviceInstaller.....	18
Network Configuration.....	19
Network Mode.....	20
Automatic IP Address Configuration.....	20
Static IP Address Configuration.....	21
Ethernet Configuration.....	21

Server Configuration.....	22
Server Configuration	23
Advanced	23
Host List Configuration	23
Retry Settings.....	24
Host Information.....	24
Channel 1 and 2 Configuration.....	24
Serial Settings	25
Connection Settings - TCP	27
Connection Settings - UDP	30
Configurable Pin Settings.....	32
Configurable Pin Functions.....	32
Apply Settings.....	33
Apply Defaults	33
5. Configuration via Telnet or Serial Port (Setup Mode)	34
Accessing Setup Mode.....	34
Telnet Connection	34
Serial Port Connection	35
Exiting Setup Mode	36
6. Setup Mode: Server Configuration	37
Server Configuration (Option 0)	37
IP Address	37
Set Gateway IP Address	38
Netmask: Number of Bits for Host Part	38
Set DNS Server IP Address	38
Change Telnet/Web-Manager Password	38
DHCP Name.....	39
7. Setup Mode: Channel Configuration	40
Channel 1 (Option 1) or Channel 2 (Option 2)	40
Baudrate	40
I/F (Interface) Mode	41
Flow	41
Port Number	42
Connect Mode	42
a) Incoming Connection	43
b) Response.....	44

c) Active Startup	44
d) Datagram Type	47
e) Modem Mode	47
Send the Escape Sequence (+++) in Modem Mode	49
Show IP addr after 'RING'	49
Auto Increment Source Port	49
Remote IP Address	50
Remote Port	50
DisConnMode	50
Flush Mode (Buffer Flushing)	51
Pack Control	51
Packing Interval.....	52
Trailing Characters.....	52
Send Characters	52
DisConnTime (Inactivity Timeout)	53
Send Characters.....	53
Telnet Terminal Type.....	53
Channel (Port) Password	53
8. Setup Mode: Advanced Settings	54
Expert Settings (Option 5)	54
TCP Keepalive time in seconds	54
ARP Cache timeout in seconds	55
CPU Performance.....	55
Disable Monitor Mode at bootup	55
HTTP Port Number	55
MTU Size	55
TCP Re-Transmission Timeout.....	56
Enable alternate MAC.....	56
Ethernet Connection Type	56
Security Settings (Option 6).....	56
Disable SNMP.....	57
SNMP Community Name.....	57
Disable Telnet Setup.....	57
Disable TFTP Firmware Upgrade	58
Disable Port 77FE (Hex)	58
Disable Web Server	58
Disable Web Setup	58

Disable ECHO Ports	58
Enable Encryption	59
Enable Enhanced Password	60
Disable Port 77F0 (Hex)	60
Default Settings (Option 7)	60
Channel 1 and Channel 2 Configuration Defaults	60
Expert Settings Defaults	61
Security Settings Defaults	61
9. GPIO Interface	62
Configurable Pins	62
Features	62
Control Protocol	63
Guidelines	63
Commands	63
Examples	65
10. Firmware Upgrades	67
Obtaining Firmware	67
Reloading Firmware	67
Using TFTP: Graphical User Interface	67
Using TFTP: Command Line Interface	68
Recovering the Firmware Using the Serial Port and DeviceInstaller	69
11. Monitor Mode	70
Entering Monitor Mode Using the Serial Port	70
Entering Monitor Mode Using the Network Port	70
Monitor Mode Commands	70
12. Troubleshooting	73
Problems and Error Messages	73
Technical Support	76
A: Binary to Hexadecimal Conversions	77
Converting Binary to Hexadecimal	77
Conversion Table	77
Scientific Calculator	77
B: Compliance	79
RoHS Notice	79

List of Tables

Table 6-1. BootP/DHCP/AutoIP Options	37
Table 6-2. Standard IP Network Netmasks	38
Table 7-1. Interface Mode Options	41
Table 7-2. RS232 Interface Mode Settings	41
Table 7-3. Flow Control Options	42
Table 7-4. Reserved Port Numbers	42
Table 7-5. Connect Mode Options	43
Table 7-6. Manual Connection Address Example	45
Table 7-7. Modem Mode Messages	47
Table 7-8. Modem Mode Commands	48
Table 7-9. Disconnect Mode Options	50
Table 7-10. Flush Mode Options	51
Table 7-11. Pack Control Options	52
Table 10-1. Firmware Files	67
Table 11-1. Monitor Mode Commands	71
Table 11-2. Command Response Codes	72

List of Figures

Figure 2-1. Product Label	13
Figure 4-1. Web-Manager Login Window	19
Figure 4-2. Lantronix Web-Manager	19
Figure 4-3. Network Settings	20
Figure 4-4. Server Settings	22
Figure 4-5. Hostlist Settings	24
Figure 4-6. Channel Serial Settings	25
Figure 4-7. TCP Connection Settings	28
Figure 4-8. UDP Connection Settings	31
Figure 4-9. Configurable Pins Settings	32
Figure 4-10. Apply Settings and Apply Defaults	33
Figure 5-1. MAC Address	35
Figure 5-2. Setup Menu Options	35
Figure 7-1. Serial Port Parameters	40
Figure 7-2. Hostlist Option	46
Figure 8-1. Expert Settings	54
Figure 8-2. Security Settings	56
Figure 10-1. TFTP Window	68

1. Using This Guide

Purpose and Audience

This guide covers xPico Device Server Module. It provides the information needed to configure, use, and update the xPico firmware and is intended for OEMs and system integrators who are embedding the xPico in their end product designs.

Chapter Summary

The remaining chapters in this guide include:

Document	Description
2: Introduction	Describes the main features of the xPico and the protocols it supports.
3: Using DeviceInstaller	Provides information for getting your unit up and running, using DeviceInstaller to assign an IP address.
4: Configuration Using Web Manager	Details using the Web-Manager to set parameters such as port and server properties.
5: Configuration via Telnet or Serial Port (Setup Mode)	Provides instructions for accessing Setup Mode (command line interface) using a Telnet connection through the network or a terminal or terminal emulation program through the serial port.
6: Setup Mode: Server Configuration	Details the network (server) settings
7: Setup Mode: Channel Configuration	Details the serial port settings.
8: Setup Mode: Advanced Settings	Details expert and security settings and explains how to reset the unit to factory default values.
9: GPIO Interface	Provides instructions for configuring the eight General Purpose I/O pins (CP1-8).
10: Firmware Upgrades	Provides instructions for obtaining the latest firmware and updating the xPico.
11: Monitor Mode	Provides instructions for accessing and using the command line interface for monitoring the network and diagnosing problems.
12: Troubleshooting	Describes common problems and error messages and how to contact Lantronix Technical Support.
A: Binary to Hexadecimal Conversions	Provides instructions for converting binary numbers to hexadecimals.
B: Compliance	Provides compliance information.

Additional Documentation

Visit the Lantronix Web site at www.lantronix.com/support/documentation for the latest documentation and the following additional documentation.

Document	Description
<i>xPico Quick Start</i>	Provides the steps for getting the xPico evaluation board up and running.
<i>xPico Integration Guide</i>	Provides information about the xPico hardware, testing the xPico using the evaluation board, and integrating the xPico into your product.
<i>xPico Development Kit Quick Start</i>	Instructions for using the xPico on the xPico evaluation board.
<i>Com Port Redirector User Guide</i>	Provides information on using the Windows-based utility to create a virtual com port.
<i>DeviceInstaller Online Help</i>	Provides information on using DeviceInstaller to configure IP addresses and locate Lantronix devices on the network.

2. Introduction

This chapter summarizes the xPico device server's features and the basic information needed to get started.

Capabilities

The xPico device server has the following capabilities:

- ◆ Connects devices through a TCP data channel or through a Telnet connection to computers or to another device server. The xPico also supports UDP datagrams.
- ◆ Contains a web [HTTP] server allowing presentation of custom content and easy configuration through a browser.
- ◆ Has eight programmable I/O pins used to monitor or control attached devices.

Applications

The xPico device server connects serial devices such as those listed below to Ethernet networks using the IP protocol family.

- ◆ ATM machines
- ◆ CNC controllers
- ◆ Data collection devices
- ◆ Environmental sensors
- ◆ Universal Power Supply (UPS) management units
- ◆ Telecommunications equipment
- ◆ Data display devices
- ◆ Security alarms and access control devices
- ◆ Handheld instruments
- ◆ Modems
- ◆ Time/attendance clocks and terminals

Protocol Support

The xPico device server uses the Internet Protocol (IP) for network communications. It uses the Transmission Control Protocol (TCP) to assure that no data is lost or duplicated, and that everything sent to the connection arrives correctly at the target.

Supported protocols include:

- ◆ ARP, TCP/IP, UDP/IP, BOOTP, ICMP, Telnet, TFTP, AutoIP, DHCP, HTTP, and SNMP for network communications and management.
- ◆ TCP/IP, UDP/IP, and Telnet for connections to the serial port.
- ◆ TFTP for firmware and web page updates.
- ◆ IP for addressing, routing, and data block handling over the network.
- ◆ User Datagram Protocol (UDP) for typical datagram applications in which devices interact with other devices without maintaining a point-to-point connection.

Configuration Methods

For the unit to operate correctly on a network, it must have a unique IP address on the network. There are three basic methods for logging into the device server to assign an IP address and configure the unit:

DeviceInstaller: Assign an IP address and view the current xPico configuration using a Graphical User Interface (GUI) on a PC attached to a network. (See [3 Using DeviceInstaller](#).)

Web-Manager: Through a web interface, configure the xPico and its settings using the xPico's Web-Manager. (See [4 Configuration Using Web Manager](#))

Serial & Telnet Ports: There are two approaches to accessing Serial Mode. Make a Telnet connection to the network port (9999) or connect a terminal (or a PC running a terminal emulation program) to the unit's serial port. (See [5 Configuration via Telnet or Serial Port \(Setup Mode\)](#))

Addresses and Port Numbers

Hardware Address

The hardware address is also referred to as the Ethernet address or the MAC address. The first three bytes of the Ethernet address identify the unit as a Lantronix product. The fourth, fifth, and sixth bytes are unique numbers assigned to each unit.

Example: 00-80-A3-14-01-18

Note: Make note of the MAC address. It is needed to locate the xPico using DeviceInstaller.

IP Address

Every device connected to an IP network must have a unique IP address. This address is used to reference the specific unit. The xPico is automatically assigned an IP address on DHCP-enabled networks, as it is DHCP-enabled by default.

Port Numbers

Every TCP connection and every UDP datagram is defined by a destination IP address and a port number. For example, a Telnet application commonly uses port number 23. A port number is similar to an extension on a phone system.

The unit's serial channel (port) can be associated with a specific TCP/UDP port number. Port number 9999 is reserved for access to the unit's Setup (configuration) Mode window. Ports 0-1024 are reserved as well. For more information on reserved port numbers, see to [Table 7-4. Reserved Port Numbers](#) on page 42.

Product Information Label

The product information label on the unit contains the following information about the specific unit:

- ◆ Part Number
- ◆ Revision
- ◆ Manufacturing Date Code
- ◆ Product Model
- ◆ Country of Origin
- ◆ Lantronix Datamatrix Barcode
- ◆ MAC Address

Figure 2-1. Product Label

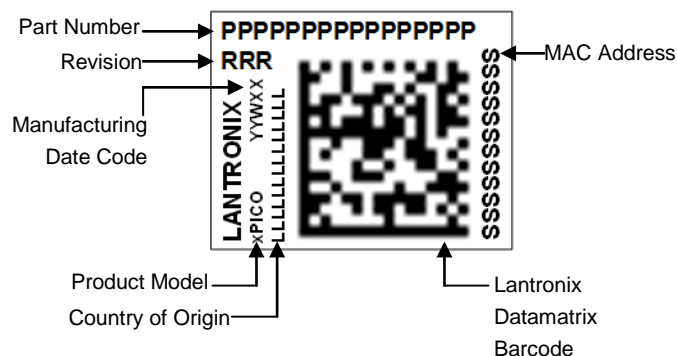

3. Using DeviceInstaller

This chapter covers the steps for getting the xPico device server online and viewing its current configuration.

Note: *DeviceInstaller* is a free utility program provided by Lantronix that discovers, configures, upgrades, and manages Lantronix Device Servers. It can be downloaded from the Lantronix website at www.lantronix.com/support/downloads.

For instructions on using *DeviceInstaller* to configure the IP address and related settings or for more advanced features, see the [DeviceInstaller Online Help](#).

Installing DeviceInstaller

To install DeviceInstaller:

1. Download the latest version of DeviceInstaller from <http://www.lantronix.com/downloads>.
2. Run the executable to start the installation process.
3. Respond to the installation wizard prompts. (If prompted to select an installation type, select **Typical**).

Assigning an IP Address

The unit's IP address must be configured before it can work correctly on a network. You have several options for assigning an IP to your unit. We recommend that you manually assign the IP address over the network using DeviceInstaller.

Note: *To use a serial connection instead of an Ethernet connection to configure the device, see 5 Configuration via Telnet or Serial Port (Setup Mode) on page 35.*

The unit's IP address is normally set to 0.0.0.0 at the factory. The hardware address is on the product label. The unit is DHCP enabled as the default.

To assign an IP address manually:

1. Click **Start**→**Programs** → **Lantronix**→**DeviceInstaller**→**DeviceInstaller**. If your PC has more than one network adapter, a message displays. Select an adapter and click **OK**.

Note: *If the unit already has an IP address (e.g., DHCP has assigned an IP address), click the **Search** icon and select the unit from the list of Lantronix device servers on the local network.*

2. Click the **Assign IP** icon .
 3. If prompted, enter the hardware address (on the product label) and click **Next**.
 4. Select **Assign a specific IP address** and click **Next**.
 5. Enter the **IP address**. The **Subnet mask** displays automatically based on the IP address; if desired, you may change it. On a local network, you can leave the **Default gateway** blank (all zeros). Click **Next**.
 6. Click the **Assign** button and wait several seconds until a confirmation message displays. Click **Finish**.
 7. Select the device from the main window list and select **Ping** from the **Tools** menu. The Ping Device dialog box shows the IP address of the selected unit.
 8. From the **Tools** menu, click the **Ping** button. The results display in the Status window. Click the **Clear Status** button to clear the window so you can ping the device again.
- Note:** If you do not receive “Reply” messages, make sure the unit is properly attached to the network and that the IP address assigned is valid for the particular network segment you are working with. If you are not sure, check with your systems administrator.*
9. Click the **Close** button to close the dialog box and return to the main window.

Accessing the xPico Using DeviceInstaller

1. Click **Start**→**Programs** → **Lantronix**→**DeviceInstaller**→**DeviceInstaller**.
2. Click the **xPico** folder. The list of available Lantronix xPico modules display.
3. Expand the list of xPicos by clicking the + symbol next to the xPico icon. Select the xPico unit by clicking on its IP address to view its configuration.

Viewing the Current Configuration

DeviceInstaller provides a view of the unit's configuration.

To view the unit's current settings:

1. Follow the instructions above to locate the xPico.
2. In the right pane, click the **Device Details** tab. The current xPico configuration displays:

Name	Configurable field. A name that identifies the xPico. Double-click the field, type in the value, and press Enter to complete. This name is not visible on other PCs or laptops using DeviceInstaller.
-------------	---

DHCP Device Name	Non-configurable field. Displays the name associated with xPico's current IP address, if the IP address was obtained dynamically. To change the DHCP device name, see Configuration Using Web Manager or Configuration via Telnet or Serial Port (Setup Mode) .
Group	Configurable field. A group name to categorize the xPico. Double-click the field, type in the value, and press Enter to complete. This group name is not visible on other PCs or laptops using DeviceInstaller.
Comments	Configurable field. Information about the xPico. Double-click the field, type in the value, and press Enter to complete. This description or comment is not visible on other PCs or laptops using DeviceInstaller.
Device Family	Non-configurable field. Displays the xPico's device family as xPico.
Type	Non-configurable field. Displays the device type as xPico.
ID	Non-configurable field. Displays the xPico's ID embedded within the unit.
Hardware Address	Non-configurable field. Displays the xPico's hardware (or MAC) address.
Firmware Version	Non-configurable field. Displays the firmware currently installed on the xPico.
Extended Firmware Version	Non-configurable field. Displays the full version nomenclature of the firmware.
Online Status	Non-configurable field. Displays the xPico's status as online, offline, unreachable (the xPico is on a different subnet), or busy (the xPico is currently performing a task).
IP Address	Non-configurable field. Displays the xPico's current IP address. To change the IP address, see Assigning an IP Address on page 14.
IP Address was Obtained	Displays "Dynamically" if the xPico automatically received an IP address (e.g., from DHCP). Displays "Statically" if the IP address was configured manually. If the IP address was assigned dynamically, the following fields appear: <ul style="list-style-type: none"> ◆ Obtain via DHCP with value of True or False. ◆ Obtain via BOOTP with value of True or False. ◆ Obtain via RARP with value of True or False ◆ Obtain via Auto IP with value of True or False
Subnet Mask	Non-configurable field. Displays the xPico's current subnet mask. To change the subnet mask, see Assigning an IP Address on page 14.
Gateway	Non-configurable field. Displays the xPico's current gateway. To change the gateway, see Assigning an IP Address on page 14.
Number of COB partitions supported	Non-configurable field. Displays the number of COB partitions supported.
Number of Ports	Non-configurable field. Displays the number of ports on the xPico.
TCP Keepalive	Non-configurable field. Displays 1-65s, the xPico's TCP keepalive value. The default setting is 45.

Telnet Supported	Non-configurable field. Indicates if Telnet sessions are permitted.
Telnet Port	Non-configurable field. Displays the xPico's port for Telnet sessions.
Web Port	Non-configurable field. Displays the xPico's port for Web-Manager configuration.
Maximum Baud Rate Supported	Non-configurable field. Displays the xPico's maximum baud rate. <i>Note: the xPico may not currently be running at this rate.</i>
Firmware Upgradeable	Non-configurable field. Displays True, indicating the xPico's firmware is upgradeable as newer version become available.
Supports Configurable Pins	Non-configurable field. Displays True, indicating configurable pins are available on the xPico.
Supports Email Triggers	Non-configurable field. Displays False, indicating email triggers are not supported on xPico.
Supports AES Data Stream	Non-configurable field. Displays True. xPico supports AES encryption.
Supports 485	Non-configurable field. Displays True. xPico supports the RS-485 protocol.
Supports 921K Baud Rate	Non-configurable field. Displays True. xPico supports baud rates up to 921600 bits per second (bps).
Supports HTTP Server	Non-configurable field. Displays True.
Supports HTTP Setup	Non-configurable field. Displays True.
Supports 230K Baud Rate	Non-configurable field. Displays True.
Supports GPIO	Non-configurable field. Displays True, indicating the xPico supports General Purpose Input Output (GPIO).

4. Configuration Using Web Manager

You must configure the unit so that it can communicate on a network with your serial device. For example, you must set the way the unit will respond to serial and network traffic, how it will handle serial packets, and when to start or close a connection.

The unit's configuration is stored in nonvolatile memory and is retained without power. You can change the configuration at any time. The unit performs a reset after you change and store the configuration.

In this chapter, we describe how to configure the xPico using Web-Manager, Lantronix's browser-based configuration tool. (For information on using Setup Mode, our command line configuration interface, see [5 Configuration via Telnet or Serial Port \(Setup Mode\)](#)).

Note: The examples in this section show a typical device. Your device may have different configuration options.

Accessing Web-Manager Using DeviceInstaller

Note: For more information on DeviceInstaller, see [3 Using DeviceInstaller](#).

1. Run DeviceInstaller and search for the list of available Lantronix device servers.
2. Click on the **xPico** folder. The list of available xPicos displays.
3. Expand the list of xPicos by clicking the **+** symbol next to the **xPico** icon.
4. Select the xPico unit by clicking its hardware address.
5. In the right pane, click the **Web Configuration** tab.
6. To view the xPico's Web-Manager in the current DeviceInstaller window, click the **Go** button. To open the Web-Manager in a web browser, click the **External Browser** button.

Note: Alternatively, to open Web-Manager, open your web browser and enter the IP address of the xPico.

A dialog box appears to prompt for a **User Name** and **Password**.

Figure 4-1. Web-Manager Login Window

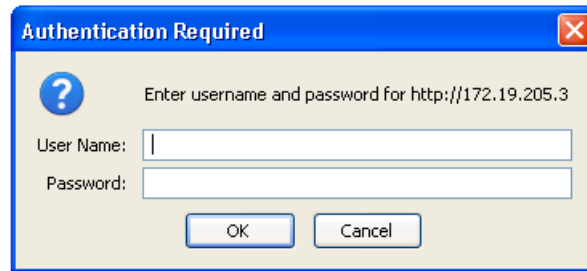

7. Perform one of the following:
 - ◆ If no Telnet password has been defined (default), leave both fields blank and click **OK**.
 - ◆ If a Telnet password has been defined, leave the username blank, type in the password, and then click **OK**.

The Web-Manager displays.

Figure 4-2. Lantronix Web-Manager



The main menu is in the left pane of the Web-Manager window.

Network Configuration

The unit's network values display when you select **Network** from the main menu. The following sections describe the configurable parameters on the Network Settings page.

Figure 4-3. Network Settings

Network Settings

Network Mode: Wired Only ▼

IP Configuration

Obtain IP address automatically

Auto Configuration Methods

BOOTP: Enable Disable

DHCP: Enable Disable

AutoIP: Enable Disable

DHCP Host Name:

Use the following IP configuration:

IP Address:

Subnet Mask:

Default Gateway:

DNS Server:

Ethernet Configuration

Auto Negotiate

Speed: 100 Mbps 10 Mbps

Duplex: Full Half

Network Mode

1. Click **Network** from the main menu.
2. Note the following:

Network Mode	Wired Only is the only choice. It enables the Ethernet network connectivity.
--------------	---

Automatic IP Address Configuration

An IP address can be assigned automatically. You then enter related network settings.

To assign an IP address automatically:

1. On the main menu, click **Network**.
2. Select **Obtain IP address automatically**.
3. Enter the following (as necessary):

BOOTP	Select Enable to permit the Bootstrap Protocol (BOOTP). server to assign the IP address from a pool of addresses automatically. Enable is the default.
DHCP	Select Enable to permit the Dynamic Host Configuration

	Protocol (DHCP) to assign a leased IP address to the xPico unit automatically. Enable is the default.
AutoIP	Select Enable to permit the xPico to generate an IP in the 169.254.x.x address range with a Class B subnet. Enable is the default.
DHCP Host Name	Enter the desired host name for the xPico.

Note: Disabling BOOTP, DHCP, and AutoIP (all three checkboxes) is not advised as the only available IP assignment method will then be ARP or serial port.

- When you are finished, click the **OK** button.
- On the main menu, click **Apply Settings**.

Static IP Address Configuration

You manually assign an IP address to the unit and enter related network settings.

To assign an IP address manually:

- On the main menu, click **Network**.
- Select **Use the following IP configuration**.
- Enter the following (as necessary):

IP Address	If DHCP is not used to assign IP addresses, enter it manually in decimal-dot notation. The IP address must be set to a unique value in the network.
Subnet Mask	A subnet mask defines the number of bits taken from the IP address that are assigned for the host part.
Default Gateway	The gateway address, or router, allows communication to other LAN segments. The gateway address should be the IP address of the router connected to the same LAN segment as the unit. The gateway address must be within the local network.
DNS Server	The DNS server allows the name of a remote machine to be resolved automatically. Enter the IP address of the DNS server. If the device is DHCP enabled, the DHCP server provides the DNS server IP address, which will override this configured value. Note: This setting is applicable only in Manual Connection mode.

- When you are finished, click the **OK** button.
- On the main menu, click **Apply Settings**.

Ethernet Configuration

You must specify the speed and direction of data transmission.

To specify how data will be transmitted:

- On the main menu, click **Network**.
- Enter the following (as necessary):

Auto Negotiate	<p>With this option, the Ethernet port auto-negotiates the speed and duplex with the hardware endpoint to which it is connected. This is the default.</p> <p>If this option is not selected, the complete the fields that become available:</p> <ul style="list-style-type: none"> ◆ Speed: The speed of data transmission. The default is 100 Mbps. ◆ Duplex: The direction of data transmission. The default is Full.
-----------------------	---

3. When you are finished, click the **OK** button.
4. On the main menu, click **Apply Settings**.

Server Configuration

The unit's server values display when you select **Server** from the main menu. The following sections describe the configurable parameters on the Server Settings page.

Figure 4-4. Server Settings

Server Settings

Server Configuration

Advanced Password: Enable Disable

Telnet/Web Manager Password:

Retype Password:

Advanced

ARP Cache Timeout (secs):

TCP Keepalive (secs):

Monitor Mode @ Bootup: Enable Disable

CPU Performance Mode: Low Regular High

HTTP Server Port:

Config Server Port:

MTU Size:

TCP Re-transmission timeout (ms):

To configure the xPico's device server settings:

1. On the main menu, click **Server**.
2. Configure or modify the following fields:

Server Configuration

Advanced Password	Select whether to enable advanced password: <ul style="list-style-type: none"> ♦ Enable: selecting this option enables advanced password creation, allowing you to create passwords up to 16 bytes in length. ♦ Disable: selecting this option disables advanced password creation, allowing you to create basic passwords up to 4 bytes in length.
Telnet/Web Manager Password	Enter the password required for Telnet configuration and Web Manager access.
Retype Password	Re-enter the password required for Telnet configuration and Web Manager access.

Advanced

ARP Cache Timeout	When the unit communicates with another device on the network, it adds an entry into its ARP table. ARP Cache timeout defines the number of seconds (1-600) before it refreshes this table.
TCP Keepalive	TCP Keepalive time defines how many seconds the unit waits during an inactive connection before checking its status. If the unit does not receive a response, it drops that connection. Enter a value between 0 and 60 seconds. 0 disables keepalive. The default setting is 45 .
Monitor Mode @ Bootup	Select Disable to disable entry into the monitor mode using the ' yyy ' or ' xx1 ' key sequence at startup. This field prevents the unit from entering monitor mode by interpreting the stream of characters that are received during the device server's initialization at startup.
CPU Performance Mode	Select the xPico's performance mode. Higher performance settings require more energy. Regular is 48 Mhz; High is 88 Mhz. The default is Regular .
HTTP Server Port	This option allows the configuration of the web server port number. The valid range is 1-65535 . The default port is 80 .
Config Server Port	Not applicable for this product.
MTU Size	The Maximum Transmission Unit (MTU) is the largest physical packet size a network can transmit for TCP and UDP. Enter between 512 and 1400 bytes. The default is 1400 bytes.
TCP Re-transmission timeout (ms)	The desired TCP re-transmission timeout value. If the ACK is not received for a packet sent from the xPico device, then the unit will retransmit the data. The valid range is 500-4000 msec.

3. When you are finished, click the **OK** button.
4. On the main menu, click **Apply Settings**.

Host List Configuration

The xPico scrolls through the host list until it connects to a device listed in the host list table. After a successful connection, the unit stops trying to connect to any others. If this connection fails, the unit continues to scroll through the table until the next successful connection.

The host list supports a minimum of 1 and a maximum of 12 entries. Each entry contains an IP address and a port number.

Note: The host list is disabled for Manual and Modem Mode. The unit does not accept a data connection from a remote device when the hostlist option is enabled.

To configure the xPico's host list:

1. On the main menu, click **Hostlist**.

Figure 4-5. Hostlist Settings

Hostlist Settings

Retry Settings

Retry Counter: Retry Timeout:

Host Information

No.	Host Address	Port	No.	Host Address	Port
1	<input type="text" value="0.0.0.0"/>	<input type="text" value="0"/>	2	<input type="text" value="0.0.0.0"/>	<input type="text" value="0"/>
3	<input type="text" value="0.0.0.0"/>	<input type="text" value="0"/>	4	<input type="text" value="0.0.0.0"/>	<input type="text" value="0"/>
5	<input type="text" value="0.0.0.0"/>	<input type="text" value="0"/>	6	<input type="text" value="0.0.0.0"/>	<input type="text" value="0"/>
7	<input type="text" value="0.0.0.0"/>	<input type="text" value="0"/>	8	<input type="text" value="0.0.0.0"/>	<input type="text" value="0"/>
9	<input type="text" value="0.0.0.0"/>	<input type="text" value="0"/>	10	<input type="text" value="0.0.0.0"/>	<input type="text" value="0"/>
11	<input type="text" value="0.0.0.0"/>	<input type="text" value="0"/>	12	<input type="text" value="0.0.0.0"/>	<input type="text" value="0"/>

2. Enter or modify the following fields:

Retry Settings

Retry Counter	Enter the value for the number of times the xPico should attempt to retry connecting to the host list.
Retry Timeout	Enter the duration (in milliseconds) the xPico should abandon attempting a connection to the host list.

Host Information

Host Address	Enter or modify the host's IP address.
Port	Enter the target port number.

3. When you are finished, click the **OK** button.
4. On the main menu, click **Apply Settings**.

Channel 1 and 2 Configuration

The Channel 1 and Channel 2 configuration define how the serial ports respond to network and serial communication.

Note: Directions for configuring Channel 1 serial settings and connection apply for Channel 2 configuration, except where indicated.

Serial Settings

To configure the channel's serial settings:

1. On the main menu, click **Serial Settings** (under **Channel 1**) to display the Serial Settings window.

Figure 4-6. Channel Serial Settings

Serial Settings

Channel 1

Disable Serial Port

Port Settings

Protocol: RS232 Flow Control: None

Baud Rate: 9600 Data Bits: 8 Parity: None Stop Bits: 1

Pack Control

Enable Packing

Idle Gap Time: 12 msec

Match 2 Byte Sequence: Yes No Send Frame Immediate: Yes No

Match Bytes: 0x00 0x00 Send Trailing Bytes: None One Two
(Hex)

Flush Mode

Flush Input Buffer

With Active Connect: Yes No

With Passive Connect: Yes No

At Time of Disconnect: Yes No

Flush Output Buffer

With Active Connect: Yes No

With Passive Connect: Yes No

At Time of Disconnect: Yes No

OK

2. In the available fields, enter the following information:

Channel 1

Disable Serial Port	When selected, disables communication through the serial port. The serial port is enabled by default. Note: This checkbox only applies to Channel 2.
----------------------------	--

Port Settings

Protocol	From the drop-down menu, select the protocol type for the selected channel. <ul style="list-style-type: none"> ◆ Channel 1: RS232, RS422/RS485 – 4 wire or RS485 – 2 wire protocols. ◆ Channel 2: RS232 only
Flow Control	Flow control manages data flow between devices in a network to ensure it is processed efficiently. Too much data arriving before a

	<p>device is prepared to manage it causes lost or retransmitted data. None is the default.</p> <ul style="list-style-type: none"> ◆ Channel 1: None, Xon/Xoff, Xon/Xoff Pass Chars to Host or CTS/RTS (hardware). ◆ Channel 2: None, Xon/Xoff or Xon/Xoff Pass Chars to Host
Baud Rate	<p>The unit and attached serial device, such as a modem, must agree on a speed or baud rate to use for the serial connection. Valid baud rates are 300, 600, 1200, 2400, 4800, 9600 (default), 19200, 38400, 57600, 115200, or 230400, 460800, or 921600</p> <p>Note: <i>It is recommended to use hardware flow control for baud rates of 38400 and higher or it could result in data loss.</i></p>
Data Bits	Indicates the number of bits in a transmitted data package. The default is 8.
Parity	Checks for the parity bit. The default is None.
Stop Bits	The stop bit follows the data and parity bits in serial communication. It indicates the end of transmission. The default is 1.

Pack Control

Enable Packing	<p>Select to enable packing on the xPico.</p> <p>Two firmware-selectable packing algorithms define how and when packets are sent to the network.</p> <p>The standard algorithm is optimized for applications in which the unit is used in a local environment, allowing for very small delays for single characters, while keeping the packet count low.</p> <p>The alternate packing algorithm minimizes the packet count on the network and is especially useful in applications in a routed Wide Area Network (WAN). Adjusting parameters in this mode can economize the network data stream.</p> <p>Disabled by default.</p>
Idle Gap Time	Select the maximum time for inactivity. The default time is 12 milliseconds.
Match 2 Byte Sequence	Use to indicate the end of a series of data to be sent as one group. The sequence must occur sequentially to indicate end of the data collection to the xPico. The default is No .
Match Bytes	Use to indicate the end of a series of data to be sent as one group. Set this value to 00 if specific functions are not needed.
Send Frame Immediate	After the detection of the byte sequence, indicates whether to send the data frame or the entire buffer. Select Yes to send only the data frame. The default setting is No .
Send Trailing Bytes	Select the number of bytes to send after the end-of-sequence characters. The default is None .

Flush Input Buffer (Serial to Network)

With Active Connect	Select Yes to clear the input buffer with a connection that is initiated from the device to the network. The default is No .
With Passive Connect	Select Yes to clear the input buffer with a connection initiated

	from the network to the device. The default is No .
At Time of Disconnect	Select Yes to clear the input buffer when the network connection to or from the device is disconnected. The default is No .

Flush Output Buffer (Network to Serial)

With Active Connect	Select Yes to clear the output buffer with a connection that is initiated from the device to the network. The default is No .
With Passive Connect	Select Yes to clear the output buffer with a connection initiated from the network to the device. The default is No .
At Time of Disconnect	Select Yes to clear the output buffer when the network connection to or from the device is disconnected. The default is No .

3. When you are finished, click the **OK** button.
4. On the main menu, click **Apply Settings**.

Connection Settings - TCP

To configure a channel's TCP settings:

1. On the main menu, click **Connection**. The Connection Settings window for the channel displays.

Figure 4-7. TCP Connection Settings

Connection Settings	
Channel 1	
Connect Protocol	
Protocol: <input type="text" value="TCP"/>	
Connect Mode	
Passive Connection:	Active Connection:
Accept Incoming: <input type="text" value="Yes"/>	Active Connect: <input type="text" value="None"/>
Password Required: <input type="radio"/> Yes <input checked="" type="radio"/> No	Start Character: <input type="text" value="0x0D"/> (in Hex)
Password: <input type="text"/>	Modem Mode: <input type="text" value="None"/>
Modem Escape Sequence Pass Through: <input checked="" type="radio"/> Yes <input type="radio"/> No	Show IP Address After RING: <input checked="" type="radio"/> Yes <input type="radio"/> No
Endpoint Configuration:	
Local Port: <input type="text" value="10001"/>	<input type="checkbox"/> Auto increment for active connect
Remote Port: <input type="text" value="0"/>	Remote Host: <input type="text" value="0.0.0.0"/>
Common Options:	
Telnet Com Port Cntrl: <input type="text" value="Disable"/>	Connect Response: <input type="text" value="None"/>
Terminal Name: <input type="text"/>	Use Hostlist: <input type="radio"/> Yes <input checked="" type="radio"/> No
	LED: <input type="text" value="Blink"/>
Disconnect Mode	
On Mdm_Ctrl_In Drop: <input type="radio"/> Yes <input checked="" type="radio"/> No	Hard Disconnect: <input checked="" type="radio"/> Yes <input type="radio"/> No
Check EOT(Ctrl-D): <input type="radio"/> Yes <input checked="" type="radio"/> No	Inactivity Timeout: <input type="text" value="0"/> : <input type="text" value="0"/> (mins : secs)
<input type="button" value="OK"/>	

2. In the available fields, enter or modify the following information:

Connect Protocol

Protocol	From the drop-down menu, select TCP .
-----------------	--

Connect Mode: Passive Connection

Accept Incoming	Select Yes to accept incoming connections. The default is Yes .
Required	Determines whether a password is required for an incoming passive connection. This field is not available when a password is set for Telnet mode.
Password	If Password Required was set to Yes , enter the password for passive connections.

Connect Mode: Active Connection

Active Connect	Select None to disable Active Connect . Otherwise, indicate the connection type from the drop-down list: <ul style="list-style-type: none"> ◆ With Any Character: Attempts to connect when any character is received from the serial port. ◆ With Active Mdm Ctrl In: Accepts external connection requests only when the Modem Control In input is asserted. ◆ With Start Character: Attempts to connect when it receives a specific start character from the serial port. The default start character is carriage return. ◆ Manual Connection: Attempts to connect when directed by a command string received from the serial port. ◆ Auto Start: Automatically connects to the remote IP address and port after booting up.
Start Character	If Active Connect is set to With Start Character , enter the start character in this field.
Modem Mode	Indicates the on-screen response type when in Modem Mode (if Modem Mode is enabled).
Show IP Address After Ring	Indicates whether to display the remote IP address upon connection. The default setting is Yes .

Endpoint Configuration

Local Port	Enter the local port number.
Auto increment for active connect	Select to auto-increment the local port number for new outgoing connections. The range of auto-incremented port numbers is 50,000 to 59,999 and loops back to the beginning when the maximum range is reached.
Remote Port	Enter the remote port number.
Remote Host	Enter the IP address of the remote device.

Common Options

Telnet Com Port Cntrl	<i>This field is available for configuration only when Active</i>
------------------------------	--

	Connect is set to None . Select Enable to permit Telnet communication to the unit. The Telnet Com Port Cntrl feature is used in conjunction with the Com Port Redirector (CPR) utility. (See the CPR online Help for details.)
Terminal Name	This field is available for configuration only when Telnet Mode is set to Enable . Use the terminal name for the Telnet terminal type. Enter only one name. When this option is enabled, the unit also reacts to the end of record (EOR) and binary options, which can be used for applications such as terminal emulation to IBM hosts.
Connect Response	A single character is transmitted to the serial port when there is a change in connection state. Default setting is None .
Use Hostlist	If this option is set to True , the device server scrolls through the host list until it connects to a device listed in the host list table. Once it connects, the unit stops trying to connect to any others. If this connection fails, the unit continues to scroll through the table until it connects to another IP in the host list. The host list is disabled for Manual Mode and for Modem Mode. The unit will not accept a data connection from a remote device when the host list option is enabled.
LED	Select Blink for the status LEDs to blink upon connection or None for no LED output.

Disconnect Mode

On Mdm_Ctrl_In Drop	Set to Yes for the network connection to or from the serial port to disconnect (drop) when Modem Control In transitions from an asserted state to not asserted state. The default setting is No.
Hard Disconnect	When set to Yes , the TCP connection closes even if the remote site does not acknowledge the disconnect request.
Check EOT (Ctrl-D)	Select Yes to drop the connection when Ctrl-D or Hex 04 is detected. Both Telnet Com Port Cntrl and Check EOT (Ctrl+ D) must be enabled for Disconnect with EOT to function properly. Ctrl+D is only detected going from the serial port to the network. The default setting is No .
Inactivity Timeout	Use this parameter to set an inactivity timeout. The unit drops the connection if there is no activity on the serial line before the set time expires. Enter time in the format mm:ss, where m is the number of minutes and s is the number of seconds. To disable the inactivity timeout, enter 00:00 .

3. When you are finished, click the **OK** button.
4. On the main menu, click **Apply Settings**.

Connection Settings - UDP

To configure a channel's UDP settings:

1. On the main menu, click **Connection**. The Connection Settings window for the selected channel displays.
2. In the available fields, enter or modify the following information:

Figure 4-8. UDP Connection Settings

Connection Settings

Channel 1

Connect Protocol

Protocol:

Datagram Mode:

Datagram Type: Accept Incoming:

Endpoint Configuration:

Local Port: Remote Port:

Remote Host: Use Broadcast

Device Address Table:

No.	Dev Addr	No.	Dev Addr	No.	Dev Addr	No.	Dev Addr
0	<input type="text" value="0"/>	1	<input type="text" value="0"/>	2	<input type="text" value="0"/>	3	<input type="text" value="0"/>
4	<input type="text" value="0"/>	5	<input type="text" value="0"/>	6	<input type="text" value="0"/>	7	<input type="text" value="0"/>
8	<input type="text" value="0"/>	9	<input type="text" value="0"/>	10	<input type="text" value="0"/>	11	<input type="text" value="0"/>
12	<input type="text" value="0"/>	13	<input type="text" value="0"/>	14	<input type="text" value="0"/>	15	<input type="text" value="0"/>

Connect Protocol

Protocol	Select UDP from the drop-down menu.
-----------------	--

Datagram Mode

Datagram Type	Configures the remote IP or network broadcast address and the remote port. Enter 01 for directed or broadcast UDP. The default setting is 00 .
Accept Incoming	Select Yes to accept incoming UDP datagrams.

Endpoint Configuration

Local Port	Enter the local port number.
Remote Port	Enter the port number of the remote device.
Remote Host	Enter the IP address of the remote device.
Use Broadcast	Select to broadcast the UDP datagram. The default is not to broadcast. Note: <i>Datagrams are sent as subnet-directed broadcasts.</i>
Device Address Table	The table is enabled when Datagram Type is set to FD . Enter values between 1 and 255 to identify units on the local network of device servers. Note: <i>Lantronix Tech Support supports Datagram type 01. Datagram Type FD is for OEM use.</i>

- When you are finished, click the **OK** button.
- On the main menu, click **Apply Settings**.

Configurable Pin Settings

There are eight configurable hardware pins on the xPico unit. For each pin, configure the pin function, communication direction, and activity level. For more information, see [9 GPIO Interface](#).

To configure the xPico's Configurable Pins:

- On the main menu, click **Configurable Pins**. The Configurable Pins page opens.

Figure 4-9. Configurable Pins Settings

Configurable Pin Settings			
CP	Function	Direction	Active Level
1	General Purpose I/O	<input checked="" type="radio"/> Input <input type="radio"/> Output	<input checked="" type="radio"/> Low <input type="radio"/> High
2	General Purpose I/O	<input checked="" type="radio"/> Input <input type="radio"/> Output	<input checked="" type="radio"/> Low <input type="radio"/> High
3	General Purpose I/O	<input checked="" type="radio"/> Input <input type="radio"/> Output	<input checked="" type="radio"/> Low <input type="radio"/> High
4	General Purpose I/O	<input checked="" type="radio"/> Input <input type="radio"/> Output	<input checked="" type="radio"/> Low <input type="radio"/> High
5	General Purpose I/O	<input checked="" type="radio"/> Input <input type="radio"/> Output	<input checked="" type="radio"/> Low <input type="radio"/> High
6	General Purpose I/O	<input checked="" type="radio"/> Input <input type="radio"/> Output	<input checked="" type="radio"/> Low <input type="radio"/> High
7	General Purpose I/O	<input checked="" type="radio"/> Input <input type="radio"/> Output	<input checked="" type="radio"/> Low <input type="radio"/> High
8	General Purpose I/O	<input checked="" type="radio"/> Input <input type="radio"/> Output	<input checked="" type="radio"/> Low <input type="radio"/> High

- Configure or modify the following fields for each pin:

Function	From the drop-down menu, select the purpose of the specified pin. See Configurable Pin Functions (below) for a description of each available function.
Direction	Select whether the pin inputs or outputs.
Active Level	Select the signal active level (Low or High).

Configurable Pin Functions

General Purpose I/O	Monitors input using the 77F0 port or controls output by the 77F0 port.
Modem Ctrl Channel 1 In	For DTE device configuration this would be the DCD control line.
Modem Ctrl Channel 1 Out	For DTE device configuration this would be the DTR control line.
RS485 Select Channel 1	Optional control signal that enables toggling between RS232 and RS485 on OEM hardware design.
RS485 2-Wire Channel 1	Optional control signal that enables toggling between RS485

	2-wire and 4-wire mode on OEM hardware design.
Serial Channel 1 Status LED	Indicates channel 1 status and extended diagnostics.
Serial Channel 2 Status LED	Indicates channel 2 status and extended diagnostics.

3. When you are finished, click the **OK** button.
4. On the main menu, click **Apply Settings**.

Apply Settings

1. To save and apply the configuration changes to the device server, click the **Apply Settings** button.

Note: Clicking **OK** on each page does not change the configuration on the device. Clicking the **OK** button tells the xPico what changes to use; the **Apply Settings** button makes the changes permanent and reboots the xPico.

Apply Defaults

1. Click the **Apply Defaults** button to set the device server back to the default settings. For details see [Default Settings](#) on page 60.
2. Click **Yes** to set factory settings or click **No** to cancel.

Figure 4-10. Apply Settings and Apply Defaults



5. Configuration via Telnet or Serial Port (Setup Mode)

You must configure the unit so that it can communicate on a network with your serial device. As an alternative to using a web browser, as described in the previous chapter, you can use the following procedures remotely or locally:

- ◆ Use a Telnet connection to configure the unit over the network.
- ◆ Use a terminal or terminal emulation program to access the serial port locally.

The series of prompts at which you enter configuration settings is called **Setup Mode**.

Note: Detailed information about other setup methods is available from your Lantronix Sales Associate.

The unit's configuration is stored in nonvolatile memory and is retained without power. You can change the configuration at any time. The unit performs a reset after the configuration has been changed and stored.

This chapter tells you how to access Setup Mode and the general procedure for using it. To complete the configuration, continue with [6 Setup Mode: Server Configuration](#), [7 Setup Mode: Channel Configuration](#), and [8 Setup Mode: Advanced Settings](#).

Note: The menus in the configuration chapters show a typical device. Your device may have different configuration options.

Accessing Setup Mode

Telnet Connection

To configure the unit over the network, establish a Telnet connection to port 9999.

Note: You can also use *DeviceInstaller* to access Telnet. Select the device from the main window list, and click the **Telnet Configuration** tab. Skip steps 1 and 2.

To establish a Telnet connection:

1. From the Windows **Start** menu, click **Run** and type the following command, where x.x.x.x is the IP address, and 9999 is the unit's fixed network configuration port number:

Windows: telnet x.x.x.x 9999

UNIX: telnet x.x.x.x:9999

2. Click **OK**. The following information displays.

Figure 5-1. MAC Address

```
MAC address 0080A366000E
Software version V6.8.0.3 (120921) XPICO
AES library version 1.8.2.1

Press Enter for Setup Mode
```

3. To enter Setup Mode, **press Enter within 5 seconds**. The configuration settings display, followed by the Change Setup menu.

Figure 5-2. Setup Menu Options

```
Change Setup:
 0 Server
 1 Channel 1
 2 Channel 2
 5 Expert
 6 Security
 7 Defaults
 8 Exit without save
 9 Save and exit           Your choice ?
```

4. Select an option on the menu by entering the number of the option in the **Your choice ?** field and pressing **Enter**.
5. To enter a value for a parameter, type the value and press **Enter**, or to confirm a current value, just press **Enter**.
6. When you are finished, save the new configuration (option 9). The unit reboots.

Serial Port Connection

To configure the unit through a serial connection:

1. Connect a console terminal or PC running a terminal emulation program to your unit's serial port.
2. Set the terminal emulator serial port settings to 9600 baud, 8 bits, no parity, 1 stop bit, no flow control.

Note: *The xPico always uses these serial port settings on boot-up.*

3. Reset the xPico unit by cycling the unit's power (turning the power off and back on). Immediately upon resetting the device, enter three lowercase **x** characters (**xxx**).

Note: The easiest way to enter Setup Mode is to hold down the **x** key at the terminal (or emulation) while resetting the unit. **You must do this within three seconds of resetting the xPico.**

At this point, the screen display is the same as when you use a Telnet connection. To continue, go to step 4, above, in the section, [Telnet Connection](#)

Exiting Setup Mode

To exit setup mode:

You have two options:

- ◆ To save all changes and reboot the device, select option **9 Save and exit** from the Change Setup menu. All values are stored in nonvolatile memory.
- ◆ To exit the configuration mode without saving any changes or rebooting, select option **8 Exit without save** from the Change Setup menu.

6. Setup Mode: Server Configuration

This chapter explains how to configure the network settings.

Note: Current values appear in parentheses.

Server Configuration (Option 0)

The unit's basic network parameters display when you select **Server configuration** (option **0**). The **IP Address**, **Set Gateway IP Address**, and **Netmask** fields display the current values.

```
IP Address : (172) .(019) .(205) .(008)
Set Gateway IP Address (Y) ?
Gateway IP addr (172) .(019) .(000) .(001)
Netmask: Number of Bits for Host Part (0=default) (0)
Set DNS Server IP addr (N) ?
Change Telnet/Web Manager password (N) ?
```

IP Address

If DHCP is not used to assign IP addresses, enter the IP address manually. The IP address must be set to a unique value in the network. Enter each octet and press **Enter** between each section. The current value displays in parentheses.

```
IP Address : ( 0) ( 0) ( 0) ( 0) _
```

If DHCP is used, the third octet of the IP address sets the BootP/DHCP/AutoIP options. The following table shows the bits you can manually configure to force the xPico to disable AutoIP, DHCP, or BootP. To disable an option, set the appropriate bit.

Table 6-1. BootP/DHCP/AutoIP Options

Options	Bit
AutoIP	0
DHCP	1
BootP	2

For example, if the third octet is 0.0.5.0, the AutoIP and BootP options are disabled; only DHCP is enabled. (The value 5 results from adding the binary equivalents of 0 and 2.) This is the most common setting when using DHCP.

Set Gateway IP Address

The gateway address, or router, allows communication to other LAN segments. The gateway address should be the IP address of the router connected to the same LAN segment as the unit. The gateway address must be within the local network. The default is **N** (No), meaning the gateway address has not been set. To set the gateway address, type **Y** and enter the address.

```
Set Gateway IP Address (N) ? Y
Gateway IP addr ( 0) ( 0) ( 0) ( 0) _
```

Netmask: Number of Bits for Host Part

A netmask defines the number of bits taken from the IP address that are assigned for the host part.

```
Netmask: Number of Bits for Host Part (0=default) (0) _
```

Note: Class A: 24 bits; Class B: 16 bits; Class C: 8 bits

The unit prompts for the number of host bits to be entered, then calculates the netmask, which appears in standard decimal-dot notation (for example, 255.255.255.0) when the saved parameters display.

Table 6-2. Standard IP Network Netmasks

Network Class	Host Bits	Netmask
A	24	255.0.0.0
B	16	255.255.0.0
C	8	255.255.255.0

Set DNS Server IP Address

The DNS server allows the name of a remote machine to be resolved automatically. The default is **N** (No), indicating the DNS server address has not been set. To set the DNS server address, type **Y**. At the prompt, enter the DNS server address. If the device is DHCP enabled, the DHCP server provides the DNS server IP address, which will override this configured value.

Note: This setting is applicable only in Manual Connection mode.

```
Set DNS Server IP addr <N> ?
```

Change Telnet/Web-Manager Password

Setting the Telnet/Web-Manager password prevents unauthorized access to the setup menu through a Telnet connection to port 9999 or through web pages. The password must have 4 characters.

```
Change Telnet/Web-Manager password (N) ? _
```

An enhanced password setting (for Telnet access only) of 16 characters is available under [Security Settings \(Option 6\)](#) on page 56.

Note: You do not need a password to access the Setup Mode window by a serial connection.

DHCP Name

If a DHCP server has automatically assigned the IP address and network settings, you can discover the unit by using the DeviceInstaller network search feature.

There are three methods for assigning DHCP names to the unit.

Default DHCP Name: If you do not change the DHCP name, and you are using an IP of 0.0.0.0, then the DHCP name defaults to CXXXXXX (XXXXXX is the last 6 digits of the MAC address shown on the label on the bottom/side of the unit). For example, if the MAC address is 00-20-4A-12-34-56, then the default DHCP name is C123456.

Custom DHCP Name: You can create your own DHCP name. If you are using an IP address of 0.0.0.0, then the last option in Server configuration is **Change DHCP device name**. This option allows you to change the DHCP name to an alphanumeric name (LTX in our example).

```
Change DHCP device name (not set) ? (N) Y
Enter new DHCP device name : LTX
```

Numeric DHCP Name: You can change the DHCP name by specifying the last octet of the IP address. When you use this method, the DHCP name is LTXYY where YY is what you chose for the last octet of the IP address. If the IP address you specify is 0.0.0.12, then the DHCP name is LTX12. This method only works with 2 digit numbers (01-99).

7. Setup Mode: Channel Configuration

This chapter explains how to configure the serial port.

Channel 1 (Option 1) or Channel 2 (Option 2)

Select **Channel 1** (option 1) or **Channel 2** (option 2) from the Change Setup menu to define how the serial port responds to network and serial communications. The following sections describe the configurable parameters within the **Channel** configuration menu.

Figure 7-1. Serial Port Parameters

```
Baudrate (9600) ?
I/F Mode (4C) ?
Flow (00) ?
Port No (10001) ?
ConnectMode (C0) ?
Send '+++ ' in Modem Mode (Y) ?
Show IP addr after 'RING' (Y) ?
Auto increment source port (N) ?
Remote IP Address : (000) .(000) .(000) .(000)
Remote Port (0) ?
DisConnMode (00) ?
FlushMode (00) ?
DisConnTime (00:00) ?:
SendChar 1 (00) ?
SendChar 2 (00) ?
```

Baudrate

The unit and attached serial device, such as a modem, must agree on a speed or baud rate to use for the serial connection. Valid baud rates are 300, 600, 1200, 2400, 4800, 9600 (default), 19200, 38400, 57600, 115200, and 230400 bits per second. xPico also supports high-performance baud rates of 460800 and 921600 bits per second. (See [CPU Performance](#) on page 55).

```
Baudrate (9600) ? _
```

I/F (Interface) Mode

The Interface (I/F) Mode is a bit-coded byte entered in hexadecimal notation.

I/F Mode (4C) ? _

The following table displays available I/F Mode options:

Note: All bit positions in the table that are blank represent “don’t care” bits for that particular option, which can be set to either a 0 or 1 value.

Table 7-1. Interface Mode Options

I/F Mode Option	7	6	5	4	3	2	1	0
RS-232C ⁽¹⁾							0	0
RS-422/485							0	1
RS-485 2-wire							1	1
7 Bit					1	0		
8 Bit					1	1		
No Parity			0	0				
Even Parity			1	1				
Odd Parity			0	1				
1 stop bit	0	1						
2 stop bits ⁽¹⁾	1	1						

(1) 2 stop bits are implemented by the software. This might influence performance.

The following table demonstrates how to build some common Interface Mode settings:

Table 7-2. RS232 Interface Mode Settings

Common I/F Mode Setting	Binary	Hex
RS-232C, 8-bit, No Parity, 1 stop bit	0100 1100	4C
RS-232C, 7-bit, Even Parity, 1 stop bit	0111 1000	78

Flow

Flow control sets the local handshaking method for stopping serial input/output.

Flow (00) ? _

Use the following table to select flow control options:

Table 7-3. Flow Control Options

Flow Control Option	Hex
No flow control	00
XON/XOFF flow control	01
Hardware handshake with RTS/CTS lines	02
XON/XOFF pass characters to host	05

Port Number

The setting represents the source port number in TCP connections. It is the number that identifies the channel for remote initiating connections.

```
Port No (10001) ? _
```

The default setting for Port 1 is **10001**. The default setting for Port 2 is **10002**. The range is **1-65535**, except for the following reserved port numbers:

Table 7-4. Reserved Port Numbers

Port Numbers	Reserved for
1 – 1024	Reserved (well known ports)
9999	Telnet setup
14000-14009	Reserved for Redirector
30704	Reserved (77F0h)
30718	Reserved (77FEh)

WARNING: We recommend that you not use the reserved port numbers for this setting as incorrect operation may result.

Use Port **0** for the outgoing local port to change with each connection. The port range is **50,000** to **59,999**. Each subsequent connection increments the number by 1 (it wraps back around to 50,000).

Only use this automatic port increment feature to initiate a connection using TCP. Set the port to a non-zero value when the unit is in a passive mode or when using UDP instead of TCP.

Connect Mode

Connect Mode defines how the unit makes a connection, and how it reacts to incoming connections over the network.

```
ConnectMode (C0) ? _
```

Enter Connect Mode options in hexadecimal notation.

Note: All bit positions in the table that are blank represent “don’t care” bits, for that particular option, which can be set to either a 0 or 1 value.

Table 7-5. Connect Mode Options

Connect Mode Option	7	6	5	4	3	2	1	0
a) Incoming Connection								
Never accept incoming	0	0	0					
Accept with active Modem Control In	0	1	0					
Always Accept	1	1	0					
b) Response								
Nothing (quiet)				0				
Character response (C=connect, D=disconnect, N=unreachable)				1				
c) Active Startup								
No active startup					0	0	0	0
With any character					0	0	0	1
With active Modem Control In					0	0	1	0
With a specific start character					0	0	1	1
Manual connection					0	1	0	0
Autostart					0	1	0	1
Hostlist	0	0	1	0				
d) Datagram Type								
Directed UDP					1	1	0	0
e) Modem Mode								
No Echo			0	0		1	1	
Data Echo & Modem Response (Numeric)			0	1		1	1	1
Data Echo & Modem Response (Verbose)			0	1		1	1	0
Modem Response Only (Numeric)			0	0	1	1	1	1
Modem Response Only (Verbose)			0	0	1	1	1	0

a) Incoming Connection

Never Accept Incoming	Rejects all external connection attempts.
Accept with active Modem Control In	Accepts external connection requests only when the Modem Control In input is asserted. Cannot be used with Modem Mode.
Always Accept	Accepts any incoming connection when a connection is not already established. Default setting.

b) Response

Character Response	<p>A single character is transmitted to the serial port when there is a change in connection state: C = connected, D = disconnected, N = host unreachable. The IP address of the host connecting to the CoBos device will be provided when you use verbose mode.</p> <p>This option is overridden when the Active Start Modem Mode or Active Start Host List is in effect. Default setting is Nothing (quiet).</p>
---------------------------	---

c) Active Startup

No Active Startup	Does not attempt to initiate a connection under any circumstance. Default setting.
With Any Character	Attempts to connect when any character is received from the serial port.
With active Modem Control In	Attempts to connect when the Modem Control In input changes from not asserted to asserted.
With a Specific Start Character	Attempts to connect when it receives a specific start character from the serial port. The default start character is carriage return.

Manual Connection	<p>Attempts to connect when directed by a command string received from the serial port. The first character of the command string must be a C (ASCII 0x43), and the last character must be either a carriage return (ASCII 0x0D) or a line feed (0x0A). No blanks or space characters may be in the command string. Between the first and last command string characters must be a full or partial destination IP address and may be a destination port number.</p> <p>The IP address must be in standard decimal-dot notation and may be a partial address, representing the least significant 1, 2, or 3 bytes of the remote IP address. The period is required between each pair of IP address numbers.</p> <p>If present, the port number must follow the IP address, must be presented as a decimal number in the range 1-65535, and must be preceded by a forward slash (ASCII 0x2F). The slash separates the IP address and the port number. If you omit the port number from a command string, the internally stored remote port number starts a connection.</p> <p>If a partial IP address is presented in a command string, it is interpreted to be the least significant bytes of the IP address and uses the internally stored remote IP address to provide the most significant bytes of the IP address. If the IP address entered is 0.0.0.0/0, the device server enters Monitor Mode.</p> <p>For example, if the remote IP address already configured in the unit is 129.1.2.3, then an example command string would be C3/7. (This would connect to 129.1.2.3 and port 7.) You may also use a different ending for the connection string. For example, C50.1/23 would connect you to 129.1.50.1 and port 23.</p> <p>If an IP address does not follow the first command string character (which is "C"), the subsequent character string is interpreted as the host name and domain to be used in DNS lookup. This character string can include a destination port number as well. The port number can be preceded by either a forward slash (/) or a colon (:).</p>
--------------------------	--

Table 7-6. Manual Connection Address Example

Command String	Result if remote IP is 129.1.2.3 and remote port is 1234
C121.2.4.5/1	Complete override; connection is started with host 121.2.4.5, port 1
C5	Connects to 129.1.2.5, port 1234
C28.10/12	Connects to 129.1.28.10, port 12
C0.0.0.0/0	Enters Monitor Mode
Cwww.lantronix.com/80	Tries to connect to the Lantronix web server if the <hostname:domain> (www.lantronix.com) is configured in the DNS server database.
Autostart (Automatic Connection)	If you enable Autostart , the unit automatically connects to the remote IP address and remote port specified when the firmware starts.
Hostlist	If you enable this option, the device server scrolls through the hostlist until it connects to a device listed in the hostlist table.

Command String	Result if remote IP is 129.1.2.3 and remote port is 1234
	<p>Once it connects, the unit stops trying to connect to any others. If this connection fails, the unit continues to scroll through the table until it is able to connect to another IP in the hostlist.</p> <p>Hostlist supports a minimum of 1 and a maximum of 12 entries. Each entry contains the IP address and the port number. The hostlist is disabled for Manual and Modem Modes. The unit does not accept a data connection from a remote device when the hostlist option is enabled.</p>

Figure 7-2. Hostlist Option

```

Baudrate (9600) ?
I/F Mode (4C) ?
Flow (00) ?
Port No (10001) ?
ConnectMode (C0) ? 25
Send '+++ ' in Modem Mode (Y) ?
Show IP addr after 'RING' (Y) ?
Auto increment source port (N) ?

Hostlist :
01. IP : 172.019.205.011 Port : 00001
02. IP : 172.019.205.012 Port : 00002
03. IP : 172.019.205.013 Port : 00003

Change Hostlist ? (N) ?
Hostlist Retrycounter (3) ?
Hostlist Retrytimeout (250) ?
DisConnMode (00) ?
FlushMode (00) ?
DisConnTime (00:00) ?:
SendChar 1 (00) ?
SendChar 2 (00) ?

```

To enable the hostlist:

1. Enter a **Connect Mode** of 0x20 (2X), where **X** is any digit. The menu shows you a list of current entries already defined in the product.
2. To delete, modify, or add an entry, select **Yes**. If you enter an IP address of **0.0.0.0**, that entry and all others after it are deleted.
3. After completing the hostlist, repeat the previous step if necessary to edit the hostlist again.
4. For **Retrycounter**, enter the number of times the Lantronix unit should try to make a good network connection to a hostlist entry that it has successfully ARPed. The range is **1-15**, with the default set to **3**.
5. For **Retrytimeout**, enter the number of seconds the unit should wait before failing an attempted connection. The time is stored as units of milliseconds in the range of **10-65535**. The default is **250**.

d) Datagram Type

Directed UDP	When selecting this option, you are prompted for the Datagram type. Enter 01 for directed or broadcast UDP. Datagrams of type 01 can be sent as a broadcast by enabling the Send as Broadcast option. The default is not to broadcast. When the UDP option is in effect, the unit never attempts to initiate a TCP connection because it uses UDP datagrams to send and receive data.
---------------------	---

e) Modem Mode

In Modem (Emulation) Mode, the unit presents a modem interface to the attached serial device. It accepts AT-style modem commands and handles the modem signals correctly.

Normally, there is a modem connected to a local PC and a modem connected to a remote machine. A user must dial from the local PC to the remote machine, accumulating phone charges for each connection. Modem Mode allows you to replace modems with xPicos, and to use an Ethernet connection instead of a phone call. By not having to change communications applications, you avoid potentially expensive phone calls.

To select Modem Mode, set the Connect Mode to **C6** (no echo), **D6** (echo with full verbose), **D7** (echo with numeric response), **CF** (modem responses only, numeric response), or **CE** (modem responses only, full verbose).

Note: If the unit is in Modem Mode, and the serial port is idle, the unit can still accept network TCP connections to the serial port if Connect Mode is set to **C6** (no echo), **D6** (echo with full verbose), **D7** (echo with numeric response), **CF** (modem responses only, numeric response), or **CE** (modem responses only, full verbose).

Without Echo	<i>In Modem Mode, echo refers to the echo of all of the characters entered in command mode; it does not mean to echo data that is transferred. Quiet Mode (without echo) refers to the modem not sending an answer to the commands received (or displaying what was typed).</i>
Data Echo & Modem Response	Full Verbose: The unit echoes modem commands and responds to a command with a message string shown in the table below. Numeric Response: The unit echoes modem commands and responds to a command with a numeric response.
Modem Responses Only	Full Verbose: The unit does not echo modem commands and responds to a command with a message string shown in the table below. Numeric Response: The unit does not echo modem commands and responds to a command with a numeric response.

Table 7-7. Modem Mode Messages

Message	Meaning
Full Verbose	
OK	Command was executed without error.
CONNECT	A network connection has been established.
NO CARRIER	A network connection has been closed.
RING n.n.n.n.	A remote device, having IP address n.n.n.n, is connecting to this device.

Message	Meaning
Numeric Response	
0	OK
1	Connected
2	Ring
3	No Carrier
4	Error

Received commands must begin with the two-character sequence **AT** and be terminated with a carriage return character.

The unit ignores any character sequence received *not* starting with **AT**, and only recognizes and processes single **AT**-style commands. The unit treats compound **AT** commands as unrecognized commands.

If the **Full Verbose** option is in effect, the unit responds to an unrecognized command string that is otherwise formatted correctly (begins with **AT** and ends with carriage return) with the "OK" message and takes no further action.

If the **Numeric Response** option is in effect, the unit responds to an unrecognized command string that is otherwise formatted correctly with the "OK" message and takes no further action.

When an active connection is in effect, the unit transfers data and does not process commands received from the serial interface.

When a connection is terminated or lost, the unit reverts to command mode.

When an active connection is in effect, the unit terminates the connection if it receives the following sequence from the attached serial device:

- ◆ No serial data is received for one second.
- ◆ The character sequence +++ is received, with no more than one second between each two characters.
- ◆ No serial data is received for one second after the last + character. At this time, the unit responds affirmatively per the selected echo/response mode.
- ◆ The character string **ATH** is received, terminated with a carriage return. The unit responds affirmatively according to the selected echo/response mode and drops the network connection. The serial interface reverts to accepting command strings.

If this sequence is not followed, the unit remains in data transfer mode.

Table 7-8. Modem Mode Commands

Modem Mode Command	Function
ATDTx.x.x.x,pppp, ATDTx.x.x.x/pppp, or ATDTx.x.x.x:pppp	Makes a connection to an IP address (x.x.x.x) and a remote port number (pppp).
ATDTx.x.x.x	Makes a connection to an IP address (x.x.x.x) and the remote port number defined within the unit.

Modem Mode Command	Function
ATD0.0.0.0	Forces the unit into Monitor Mode if a remote IP address and port number are defined within the unit.
ATD or ATDT	Forces the unit into Monitor Mode if a remote IP address and port number are not defined within the unit.
ATDx.x.x.x	Makes a connection to an IP address (x.x.x.x) and the remote port number defined within the unit.
ATH	Hangs up the connection (Entered as +++ATH).
ATS0=n	Enables or disables connections from the network going to the serial port. n=0 disables the ability to make a connection from the network to the serial port. n=1-9 enables the ability to make a connection from the network to the serial port. n>1-9 is invalid.
ATEn	Enables or disables character echo and responses. n=0 disables character echo and responses. n=1 enables character echo and responses.
ATVn	Enables numeric response or full verbose. n=0 enables numeric response. n=1 enables full verbose.

Note: The unit recognizes these AT commands as single commands such as ATE0 or ATV1; it does not recognize compound commands such as ATE0V.

Send the Escape Sequence (+++) in Modem Mode

```
Send '+++' in Modem Mode (Y) ? _
```

Disable or enable the xPico's ability to send the escape sequence. The default is **Y** (Yes) (send the escape sequence).

Show IP addr after 'RING'

```
Show IP addr after 'RING' (Y)
```

Disable or enable the xPico's ability to show the IP address after RING in Modem Mode. The default is **Y** (Yes), to show the IP address.

Auto Increment Source Port

```
Auto increment source port (N) ? _
```

Y (Yes) auto increment the source port. The xPico increments the port number used with each new connection.

Remote IP Address

This is the destination IP address used with an outgoing connection.

```
Remote IP Address : (000) (000) (000) (000) _
```

Note: This option does not display when Hostlist is enabled from the ConnectMode prompt (see [Connect Mode](#) on page 42 for more information).

Remote Port

You must set the remote TCP port number for the unit to make outgoing connections. This parameter defines the port number on the target host to which a connection is attempted.

```
Remote Port (0) ? _
```

To connect an ASCII terminal to a host using the unit for login purposes, use the remote port number 23 (Internet standard port number for Telnet services).

Note: This option does not display when Hostlist is enabled from the ConnectMode prompt (see [Connect Mode](#) on page 42 for more information).

DisConnMode

This setting determines the conditions under which the unit will cause a network connection to terminate.

```
DisConnMode (00) ? _
```

Notes:

- ◆ In DisConnMode (Disconnect Mode), Modem Control In drop either drops the connection or is ignored.
- ◆ All bit positions in the table that are blank represent “don’t care” bits, for that particular option, which can be set to either a 0 or 1 value.

Table 7-9. Disconnect Mode Options

Disconnect Mode Option	7	6	5	4	3	2	1	0
Disconnect when Modem Control In is not asserted ⁽⁶⁾	1							
Ignore Modem Control In	0							
Telnet Com Port Cntrl and terminal type setup ⁽¹⁾		1						
Channel (port) password ⁽²⁾				1				
Hard disconnect ⁽³⁾					0			
Disable hard disconnect					1			

Disconnect Mode Option	7	6	5	4	3	2	1	0
State LED off with connection ⁽⁴⁾								1
Disconnect with EOT (^D) ⁽⁵⁾			1					

- (1) The **Telnet Com Port Control** feature is used in conjunction with Com Port Redirector. The unit sends the **Terminal Type** upon an outgoing connection.
- (2) A password is required for a connection to the serial port from the network.
- (3) The TCP connection closes even if the remote site does not acknowledge the disconnection.
- (4) When there is a network connection to or from the serial port, the state LED turns off instead of blinking.
- (5) When **Ctrl+D** or **Hex 04** is detected, the connection is dropped. Both **Telnet Com Port Cntrl** and **Disconnect with EOT** must be enabled for **Disconnect with EOT** to function properly. **Ctrl+D** is only detected going from the serial port to the network.
- (6) When **Modem Control In** transitions from a high state to a low state, the network connection to or from the serial port drops.

Flush Mode (Buffer Flushing)

Using this parameter, you can control line handling and network buffers with connection startup and disconnect.

```
FlushMode (00) ? _
```

You can also select between two different packing algorithms.

Note: All bit positions in the table that are blank represent “don’t care” bits, for that particular option, which can be set to either a 0 or 1 value.

Table 7-10. Flush Mode Options

Function	7	6	5	4	3	2	1	0
Input Buffer (Serial to Network)								
Clear with a connection initiated from the device to the network				1				
Clear with a connection initiated from the network to the device			1					
Clear when the network connection to or from the device is disconnected		1						
Output Buffer (Network to Serial)								
Clear with a connection initiated from the device to the network								1
Clear with a connection initiated from the network to the device							1	
Clear when the network connection to or from the device is disconnected						1		
Alternate Packing Algorithm (Pack Control)								
Enable	1							

Pack Control

The packing algorithms define how and when packets are sent to the network. The standard algorithm is optimized for applications in which the unit is used in a local environment, allowing for very small delays for single characters, while keeping the packet count low. The alternate packing algorithm minimizes the packet count on the network and is especially useful in applications in a routed Wide Area Network (WAN). Adjusting parameters in this mode can economize the network data stream.

Pack control settings are enabled in Flush Mode. Set this value to **00** if you do not need specific functions.

Note: All bit positions in the table that are blank represent “don’t care” bits, for that particular option, which can be set to either a 0 or 1 value.

Table 7-11. Pack Control Options

Option	7	6	5	4	3	2	1	0
Packing Interval								
Interval: 12ms							0	0
Interval: 52ms							0	1
Interval: 250ms							1	0
Interval: 5sec							1	1
Trailing Characters								
None					0	0		
One					0	1		
Two					1	0		
Send Characters								
2-Byte Send Character Sequence				1				
Send Immediately After Send chars			1					

Packing Interval

Packing Interval defines how long the unit should wait before sending accumulated characters. This wait period is between successive network segments containing data. For alternate packing, the default interval is 12 ms.

Trailing Characters

In some applications, CRC, Checksum, or other trailing characters follow the end-of-sequence character; this option helps to adapt frame transmission to the frame boundary.

Send Characters

- ◆ If **2-Byte Send Character Sequence** is enabled, the unit interprets the sendchars as a 2-byte sequence; if this option is not enabled, the unit interprets them independently.
- ◆ If **Send Immediately After Characters** is *not* set, any characters already in the serial buffer are included in the transmission after a "transmit" condition is found. If this option is set, the unit sends immediately after recognizing the transmit condition (sendchar or timeout).

Note: A transmission might occur if status information needs to be exchanged or an acknowledgment needs to be sent.

DisConnTime (Inactivity Timeout)

Use this parameter to set an inactivity timeout. The unit drops the TCP connection to the local port if there is no activity on the serial line before the set time expires. Enter time in the format mm:ss, where m is the number of minutes and s is the number of seconds.

```
DisConnTime (00:00) ?:
```

To disable the inactivity timeout, enter **00:00**. Range is 0 (disabled) to **5999** seconds (99 minutes, 59 seconds). Default is **0**.

Send Characters

Enter up to two characters in hexadecimal representation in sendchar.

```
SendChar 1 ( 0) ? _
SendChar 2 ( 0) ? _
```

If the unit receives a character on the serial line that matches one of these characters, it sends the character immediately, along with any awaiting characters, to the TCP connection. This action minimizes the response time for specific protocol characters on the serial line (for example, ETX, EOT). Setting the first sendchar to 00 disables the recognition of the characters. Alternatively, the unit can interpret two characters as a sequence (see [Pack Control](#) on page 51).

Telnet Terminal Type

This parameter displays only if you enabled the terminal type option in Disconnect Mode. With this option enabled, you can use the terminal name for the Telnet terminal type. Enter only one name.

With terminal type option enabled, the unit also reacts to the EOR (end of record) and binary options, useful for applications like terminal emulation to IBM hosts.

Channel (Port) Password

This parameter appears only if the channel (port) password option is enabled in Disconnect Mode. With this option enabled, you can set a password on the serial port.

8. Setup Mode: Advanced Settings

Expert Settings (Option 5)

Note: You can change the Enable alternate MAC setting using telnet or serial connections only. It is not available through the Web-Manager.

CAUTION: Only an expert should change these parameters. You must definitely know the consequences the changes might have.

Figure 8-1. Expert Settings

```
TCP Keepalive time in s (1s - 65s; 0s=disable): (45) ?
ARP Cache timeout in s (1s - 600s) : (600) ?
CPU performance (0=Regular, 1=Low, 2=High): (0) ?
Disable Monitor Mode @ bootup (N) ?
HTTP Port Number : (80) ?
MTU Size (512 - 1400): (1400) ?
TCP Re-transmission Timeout (500 - 4000) (ms): (500) ?
Enable alternate MAC (N) ?
Ethernet connection type: (0) ?
```

The default settings are listed below:

TCP Keepalive time in s (1s – 65s; 0s=disable)	45
ARP Cache timeout in s (1s – 600s)	600
CPU Performance	Regular
Disable Monitor Mode @ bootup	No
HTTP Port Number (1-65535)	80
MTU Size (512 – 1400)	0 (resulting in an operational value of 1400)
TCP Re-transmission Timeout	0 (resulting in an operational value of 500)
Enable alternate MAC	No (OEM use only)
Ethernet connection type	0 (resulting in auto-negotiation)

TCP Keepalive time in seconds

This option allows you to change how many seconds the unit waits during a silent connection before attempting to see if the currently connected network device is still on the network. If the unit gets no response, it drops that connection.

```
TCP Keepalive time in s (1s - 65s; 0s=disable): (45)? _
```

ARP Cache timeout in seconds

Whenever the unit communicates with another device on the network, it adds an entry into its ARP table. The ARP Cache timeout option allows you to define how many seconds (1-600) the unit will wait before timing out this table.

```
ARP Cache timeout in s (1s - 600s) : (600) ?
```

CPU Performance

This option allows you to increase the CPU performance required to use the higher baud rates on the serial interface (460800 bps and 921600 bps). The standard CPU performance mode supports up to 230400 bps.

```
CPU performance (0=Regular, 1=Low, 2=High): (0) ?
```

Notes:

- ◆ If a baud rate of 460 Kbps or 920 Kbps is set and the high performance mode is disabled, the operation of the serial channel would be out of the specified error tolerance, thereby leading to inconsistent speed settings on the two ends of the serial channel.
- ◆ *Increasing CPU clock speed consumes more power and generates more heat. This reduces the maximum operating temperature specification. See the appropriate product brief for details.*

Disable Monitor Mode at bootup

This option allows you to disable all entries into Monitor Mode during startup, except for the 'xxx' sequence. This prevents entry using **yyy**, **zzz**, **xx1**, and **yy1** key sequences (only during the bootup sequence). The default for Monitor Mode at bootup is **N** (No). (See [11 Monitor Mode](#).)

```
Disable Monitor Mode @ bootup (N) ? _
```

HTTP Port Number

This option allows the configuration of the web server port number. The valid range is 1-65535. The default HTTP port number is 80.

```
HTTP Port Number : (80) ? _
```

MTU Size

The Maximum Transmission Unit (MTU) is the largest physical packet size a network can transmit for TCP and UDP. Enter between **512** and **1400** bytes. The default is **1400** bytes.

```
MTU Size: (1400) ? _
```

TCP Re-Transmission Timeout

The TCP Re-Transmission Timeout is the interval to wait for acknowledgement of transmitted TCP segments before re-transmitting them. Enter between **500** and **4000** ms. The default is **500 ms**.

```
TCP Re-transmission Timeout (500 - 4000) (ms): (500) ?
```

Enable alternate MAC

If necessary, enable the alternate MAC address (if specified in the OEM setup record).

```
Enable alternate MAC (N) ? _
```

Ethernet Connection Type

The xPico allows for the Ethernet speed and duplex to be manually configured. Enter **0** for auto-negotiation (default). To select the speed and duplex, enter one of the following: **2** (10 MB/half duplex), **3** (10 MB/full duplex), **4** (100 MB/half duplex), or **5** (100 MB/full duplex).

```
Ethernet connection type: (0) ? _
```

Security Settings (Option 6)

Note: You can change security settings by means of Telnet or serial connections only, not on the Web-Manager. We recommend that you set security over the dedicated network or over the serial setup to prevent eavesdropping.

CAUTION: Disabling both Telnet Setup and Port 77FE will prevent users from accessing the setup menu from the network. Disabling Port 77FE also disables the Web from configuring the device.

Select **7** to configure security settings.

Figure 8-2. Security Settings

```
Disable SNMP (N) ?
SNMP Community Name (public):
Disable Telnet Setup (N) ?
Disable TFTP Firmware Update (N) ?
Disable Port 77FEh (N) ?
Disable Web Server (N) ?
Disable Web Setup (N) ?
Disable ECHO ports (Y) ?
Enable Encryption (N) ?
Enable Enhanced Password (N) ?
```

Disable Port 77F0h (N) ?

Disable SNMP

This setting allows you to disable the SNMP protocol on the unit for security reasons.

Disable SNMP (N) ? _

SNMP Community Name

The SNMP Community Name is a required field for NMS to read or write to a device. Enter a string of 1 to 13 characters.

SNMP Community Name (public): _

The default entry is **public**. The current value is displayed in parentheses.

Disable Telnet Setup

Note: If you choose to disable this option, keep in mind that disabling both Telnet Setup and Port 77FE will prevent users from accessing the setup menu from the network.

This setting defaults to the **N** (No) option. The **Y** (Yes) option disables access to Setup Mode by Telnet (port 9999). It only allows access locally using the web pages and the serial port of the unit.

Disable Telnet Setup (N) ? _

Disable TFTP Firmware Upgrade

This setting defaults to the **N** (No) option. The **Y** (Yes) option disables the use of TFTP to perform network firmware upgrades. With this option, you can download firmware upgrades over the serial port using DeviceInstaller's Recover Firmware procedure. (See [10 Firmware Upgrades](#).)

```
Disable TFTP Firmware Update (N) : _
```

Disable Port 77FE (Hex)

Note: If you choose to disable this option, keep in mind that disabling both Telnet Setup and Port 77FE will prevent users from accessing the setup menu from the network.

Port 77FE is a setting that allows DeviceInstaller, Web-Manager, and custom programs to configure the unit remotely. You may wish to disable this capability for security purposes.

```
Disable Port 77FEh (N) ? _
```

The default setting is the **N** (No) option, which enables remote configuration. You can configure the unit by using DeviceInstaller, web pages, Telnet, or serial configuration.

The **Y** (Yes) option disables remote configuration and web sites.

Note: The **Y** (Yes) option disables many of the GUI tools for configuring the unit, including the embedded Web-Manager tool.

Disable Web Server

This setting defaults to the **N** (option). The **Y** (Yes) option disables the web server.

```
Disable Web Server (N) ? _
```

Disable Web Setup

The **Y** (Yes) option disables configuration using the Web-Manager. This setting defaults to the **N** (option).

```
Disable Web Setup (N) ? _
```

Disable ECHO Ports

This setting controls whether port 7 echoes characters it receives.

```
Disable ECHO ports (Y) ? _
```

Enable Encryption

Rijndael is the block cipher algorithm chosen by the National Institute of Science and Technology (NIST) as the Advanced Encryption Standard (AES) to be used by the US government. The xPico supports 128-, 192-, and 256-bit encryption key lengths.

Note: Configuring encryption should be done through a local connection to the serial port of the xPico, or via a secured network connection. Initial configuration information, including the encryption key, is sent in clear text over the network.

To configure AES encryption on the xPico:

```
Enable Encryption (N) Y
Key length in bits (0): 128
Change Keys (N) Y
Enter Keys: **-*-*-*-*-*-*-*-*-*-*-*-*-*-*-*-*-*-*-*-*-*-*
```

1. When prompted to enable encryption, select **Y**.
2. When prompted, enter the encryption key length. The xPico supports 128-, 192-, and 256-bit encryption key lengths.
3. When prompted to change keys, select **Y**.
4. At the **Enter Keys** prompt, enter your encryption key. The encryption keys are entered in hexadecimal. The hexadecimal values are echoed as asterisks to prevent onlookers from seeing the key. Hexadecimal values are 0-9 and A-F.
 - For a 128-bit key length, enter 32 hexadecimal characters.
 - For a 192-bit key length, enter 48 hexadecimal characters.
 - For a 256-bit key length, enter 64 hexadecimal characters
5. Continue pressing **Enter** until you return to the Change Setup menu.
6. From the Change Setup menu, select option **9** to save and exit.

Encryption only applies to the port selected for data tunneling (default 10001 for Channel 1 and 10002 for Channel 2), regardless of whether you are using TCP or UDP.

Generally, one of these situations applies:

- ◆ Encrypted xPico-to-xPico communication. Be sure to configure both modules with the same encryption key.
- ◆ Third-party application to xPico-encrypted communication: xPico uses standard AES encryption protocols. To communicate successfully, products and applications on the peer side must use the same protocols and the same encryption key as the xPico.

- ◆ Lantronix Secure Com Port Redirector provides an encrypted connection from Windows-based applications to the xPico. Information about SCPR is at www.lantronix.com/device-networking/utilities-tools/scpr. A 30-day trial version of SCPR is available.

Note: Developers can license the Lantronix Encryption Library Suite. See www.lantronix.com/device-networking/utilities-tools.

Enable Enhanced Password

This setting defaults to the **N** (No) option, which allows you to set a 4-character password that protects Setup Mode by means of Telnet and web pages. The **Y** (Yes) option allows you to set an extended security password of 16-characters for protecting Telnet and Web Page access.

```
Enable Enhanced Password (Y) ? _
```

Disable Port 77F0 (Hex)

Port 77F0 is a setting that allows a custom application to query or set the eight xPico configurable pins when they are functioning as general purpose I/O (GPIO). You may want to disable this capability for security purposes. The default setting is the **N** (No) option, which enables GPIO control. The **Y** (Yes) option disables the GPIO control interface.

```
Disable Port 77F0h ? _
```

Default Settings (Option 7)

Select **7** to reset the unit's Channel 1 and Channel 2 configuration and expert settings to the default settings. The server configuration settings for IP address, gateway IP address, and netmask remain unchanged. The configurable pins' settings also remain unchanged. The specific settings that this option changes are listed below:

Channel 1 and Channel 2 Configuration Defaults

Baudrate	9600
I/F Mode	4C (1 stop bit, no parity, 8 bit, RS-232C)
Flow	00 <i>Note: Flow control option only available for Channel 1 configuration.</i>
Port number	10001 for Channel 1 10002 for Channel 2
Connect Mode	C0 (always accept incoming connection; no active connection startup)
Send '+++' in Modem Mode	Enabled
Show IP addr after 'RING'	Enabled
Auto increment source port	Disable
Hostlist retry counter	3

Hostlist retry timeout	250 (msec)
Start character for serial channel 1 (or channel 2)	0x0D (CR)
All other parameters	0

Expert Settings Defaults

TCP Keepalive time in s	45
ARP Cache timeout in s	600
CPU Performance	0 (Regular)
Monitor Mode @ bootup	Enabled
HTTP Port Number (1-65535)	80
MTU Size (512 – 1400)	0 (resulting in an operational value of 1400)
TCP Re-transmission timeout (ms)	500 (msec)
Alternate MAC	Disabled (for OEM use only)
Ethernet Connection Type	0 (auto-negotiate)

Security Settings Defaults

Disable SNMP	No
SNMP community name	public
Disable Telnet setup	No
Disable TFTP Firmware Update	No
Disable Port 77FEh	No
Disable Web Server	No
Disable Web Setup	No
Disable ECHO ports	Yes
Enable Encryption	No
Enable Enhanced Password	No
Disable Port 77F0h	No

9. GPIO Interface

Configurable Pins

The xPico has eight pins (CP1-8) that you can configure for General Purpose I/O (GPIO).

Note: You can also configure the pins for serial port control lines, such as hardware control, modem control (CTS, RTS, DTR, and DCD), and diagnostic outputs to LED, using DeviceInstaller.

You can use these GPIO pins to control devices such as relays, servers, lights, monitor switches, sensors, and even processes such as data transfer.

You can set the functions for the eight pins independently and in any combination. The initial directions (input/output) and active levels (active low or high) at boot up can also be configured through 77FE, for example, by using DeviceInstaller.

This chapter describes how the directions, active levels, and states can be dynamically controlled and probed through special port 77F0.

The configurable pins default configuration is:

Function: General Purpose Input

Active Level: Active Low

Features

- ◆ TCP and UDP can be used.
- ◆ The protocol supports up to 32 GPIO for future products.
- ◆ Function configuration can be retrieved.
- ◆ Input or output selection can be retrieved and controlled.
- ◆ Active low or high selection can be retrieved and controlled.
- ◆ Active or inactive selection can be retrieved and controlled.
- ◆ 77F0 can be disabled.

Every change of state (active/inactive) requires a command over TCP or UDP, and thus is not very fast. If you use this port for data transfer, the throughput is low, usually up to 1 Kbps.

Control Protocol

The GPIO control protocol is a simple, proprietary protocol.

Guidelines

The GPIO control protocol is described from the PC side. Send means from PC to xPico. Response comes from xPico to PC.

The protocol allows for control of up to 32 GPIOs. How many are actually available depends on the product. xPico has only eight.

The parameters are four bytes long and represent GPIOs 0-31, with GPIO0 in bit 0 of the first byte (Little Endian). Parameter bits for configurable pins not configured as GPIOs are undefined for **Get** commands and ignored on **Set** commands.

Every command consists of nine bytes: one command type of one byte and two parameters of four bytes each.

Command	Parameter 1				Parameter 2			
0	1	2	3	4	5	6	7	8

On some commands, one or all parameters are ignored.

For UDP, command type and parameters need to be in the same datagram.

Responses to valid commands are always five bytes long, consisting of the returned command byte and as parameters in the current or updated values. In case of an invalid command, only one byte with value 0FFh is returned.

Command	Parameter 1			
0	1	2	3	4

When sending a command (TCP and UDP), wait for the response before sending the next command.

Commands

Byte 0 Command Types

10h	Get functions
11h	Get directions (input or output)
12h	Get active levels (high active or low active)
13h	Get current states (active or not active)
19h	Set directions
1Ah	Set active levels
1Bh	Set current states

There is no **Set functions** command. Since the pin's function depends on the hardware in which the xPico is embedded, that configuration is only allowed using 77FE. Settings changed by any of the **Set** commands are not stored and are lost when the unit is powered down or rebooted.

Command 10h, Get Functions

Send:
No parameters

Response:
1 parameter
Bytes 1-4: Functions
Bit X 1 means general purpose I/O available to the user.
 0 means dedicated function (e.g., serial flow control, diagnostics) for configurable pin X.

Command 11h, Get Directions

Send:
No parameters

Response:
1 parameter
Bytes 1-4: Directions
Bit X 1 means GPIO X is an output.
 0 means it is an input.

Command 12h, Get Active Levels

Send:
No parameters

Response:
1 parameter
Bytes 1-4: Active levels
Bit X 1 means GPIO X is active low (0V when active, 3.3V when inactive).
 0 means it is active high (3.3V when active, 0V when inactive).

Command 13h, Get Current States

Send:
No parameters

Response:
1 parameter
Bytes 1-4: States
Bit X 1 means GPIO X is active
 0 means it is inactive.

Command 19h, Set Directions**Send:**

2 parameters

Bytes 1-4: Mask

Bit X 1 means the direction for GPIO X will be updated with the value in the second parameter.

0 means the direction for that GPIO will not change.

Bytes 5-8: New Directions

Bit X 1 means GPIO X will become an output.

0 means it will become an input.

Response:

1 parameter

Bytes 1-4: The updated directions

Command 1Ah, Set Active Levels**Send:**

2 parameters

Bytes 1-4: Mask

Bit X 1 means the direction for GPIO X will be updated with the value in the second parameter.

0 means the active type for that GPIO will not change.

Bytes 5-8: New Active Levels

Bit X 1 means GPIO X will become active low.

0 means it will become active high.

Response:

1 parameter

Bytes 1-4: Updated active levels

Command 1Bh, Set States**Send:**

2 parameters

Bytes 1-4: Mask

Bit X 1 means the state for GPIO X will be updated with the value in the second parameter.

0 means the state for that GPIO will not change.

Bytes 5-8: New States

Bit X 1 means GPIO X will become active.

0 means it will become inactive.

Response:

1 parameter

Bytes 1-4: Updated states

Examples**Example 1: PC sends command 10h to find out which configurable pins are available as GPIO.**

PC -> xPico: 10h, 00h, 00h, 00h, 00h, 00h, 00h, 00h, 00h

xPico -> PC: 10h, 03h, 00h, 00h, 00h

Command details:

10h = command 10h
 00h, 00h, 00h, 00h = ignored
 00h, 00h, 00h, 00h = ignored

Response details:

10h = response to command 10h
 03h, 00h, 00h, 00h =

bits 0 and 1 are 1 → CP1 and CP2 are configured as GPIOs.
 bit 2 is 0 → CP3 is configured as either serial control or diagnostics.
 The other bits are ignored because there are only eight configurable pins on the xPico.

Example 2: PC sends command 1Bh to change the current states of GPIO 0 and 1.

PC -> xPico: 1Bh, 01h, 00h, 00h, 00h, 00h, 00h, 00h, 00h
 xPico -> PC: 1Bh, 05h, 00h, 00h, 00h

Command details:

1Bh = command 1Bh
 01h, 00h, 00h, 00h = the mask that determines which GPIOs will be changed.

bit 0 is 1 → GPIO0 will be changed.
 bit 1 is 0 → GPIO1 will remain the same.

00h, 00h, 00h, 00h = the new states

bit 0 is 0 → GPIO0 will become 0.
 bit 1 is ignored since it is masked out.

Response details:

1Bh = response to command 1Bh
 05h, 00h, 00h, 00h =

bit 0 is 1 → GPIO0 = 1
 bit 1 is 0 → GPIO1 = 0
 bit 2 is 1 → GPIO2 = 1
 The other bits are ignored because there are only eight configurable pins on the xPico.

10. Firmware Upgrades

Obtaining Firmware

You can obtain the most up-to-date firmware and release notes for the unit from the Lantronix web site (www.lantronix.com/support/downloads) or by using anonymous FTP ([ftp.lantronix.com/pub](ftp://lantronix.com/pub)).

Reloading Firmware

There are several ways to update the unit's internal operational code (*.ROM): using DeviceInstaller (the preferred way), using TFTP, or using the serial port. You can also update the unit's internal Web interface (*.COB) using TFTP or DeviceInstaller.

Here are typical names for those files. Check the Lantronix web site for the latest versions and release notes.

Table 10-1. Firmware Files

ROM File	COB
xpico_6800.rom	xpico_webm_1900.cob

Please refer to the DeviceInstaller online Help for information about reloading firmware using DeviceInstaller. The other methods are discussed below.

Using TFTP: Graphical User Interface

To download new firmware from a computer:

1. Use a TFTP client to put a binary file to the unit (*.ROM to upgrade the unit's internal operational code and *.COB to upgrade its internal web interface).

Note: TFTP requires the **.rom** (binary) version of the unit's internal operational code.

2. In the **Host** field, enter the IP address of the unit being upgraded.
3. In the **Port** field, enter **69**.
4. Enter the full path of the firmware file in the **Local File** field.
5. In the **Remote File** field, enter the **current** internal operational code or **WEB1** to **WEB6** for the internal web interface.

Figure 10-1. TFTP Window

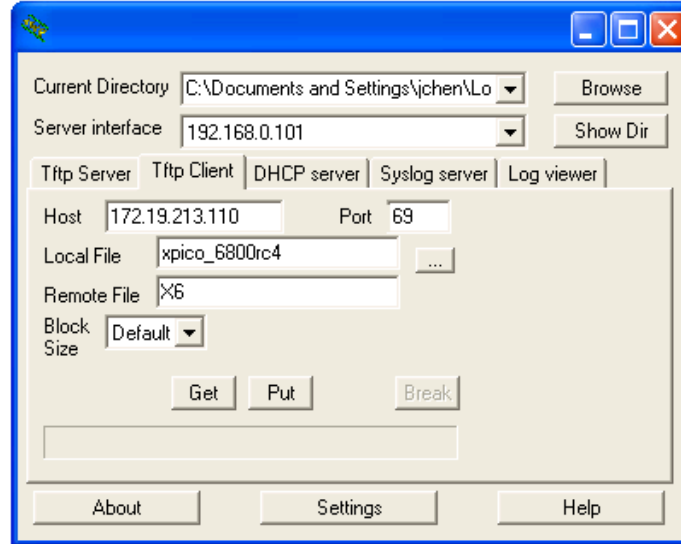

- Click the **Put** button to transfer the file to the unit. The unit performs a power reset after the firmware has been loaded and stored.

After the firmware has been loaded and stored, which takes approximately 8 seconds to complete, the unit performs a power reset.

Using TFTP: Command Line Interface

To download new firmware from a computer:

- Enter the following from a TFTP command line interface:

```
tftp -i <ip address> put <local filename> <destination file name>
```

The following examples demonstrate the TFTP command sequence to download the .rom file and the .cob file:

```
tftp -i 192.168.1.111 put xpico_6800 X6
tftp -i 192.168.1.111 put xpico_webm_1900.cob WEB1
```

Recovering the Firmware Using the Serial Port and DeviceInstaller

If for some reason the firmware is damaged, you can recover the firmware file by using DeviceInstaller to download the *.ROM file over the serial port.

To recover firmware:

1. Start DeviceInstaller. If your PC has more than one network adapter, a message displays. Select an adapter and click **OK**.
2. From the **Tools** menu, select **Advanced/Recover Firmware**. The Serial Port Firmware Upgrade window displays.
3. For **Port on PC**, enter the COM port on the PC that is connected to the serial port of the Lantronix unit.
4. For **Device Model**, be sure the appropriate xPico module is shown (xPico).
5. For **Firmware File**, click the **Browse** button and go to the location where the firmware file resides.

Note: Make sure the xPico on which you are recovering firmware is connected to this selected port on your PC.

6. Click **OK** to download the file.
7. When prompted, reset the device. Status messages and a progress bar at the bottom of the screen show the progress of the file transfer. When the file transfer completes, the message “**Successful, Click OK to Close**” appears.
8. Click the **OK** button to complete this procedure.

Note For more information, see *Recovering Firmware in the DeviceInstaller online Help*.

11. Monitor Mode

Monitor Mode is a command-line interface used for diagnostic purposes.

There are two ways to enter Monitor Mode: locally using the serial port or remotely using the network.

Entering Monitor Mode Using the Serial Port

To enter Monitor Mode locally:

1. Follow the same steps used for setting the serial configuration parameters (see [Serial Port](#) on page 35).
2. Instead of typing three **x** keys, however:
3. Type **zzz** (or **xx1**) to enter Monitor Mode with network connections.
4. Type **yyy** (or **yy1**) to enter Monitor Mode without network connections.

A **0>** prompt indicates that you have successfully entered Monitor Mode.

Entering Monitor Mode Using the Network Port

To enter Monitor Mode using a Telnet connection:

1. Establish a Telnet session to the configuration port (9999). The following message appears:

```
MAC address 0080A366000E
Software version V6.8.0.0RC4 (120327) XPICO
AES library version 1.8.2.1

Press Enter for Setup Mode
```

2. Type **M** (upper case).

A **0>** prompt indicates that you have successfully entered Monitor Mode.

Monitor Mode Commands

The following commands are available in Monitor Mode. Many commands have an IP address as an optional parameter (xxx.xxx.xxx.xxx). If you enter the IP address, the command is applied to another unit with that IP address. If you do not enter the IP address, the command is executed locally.

Note: All commands must be in capital letters. Responses to some of the commands are in Intel Hex format.

Table 11-1. Monitor Mode Commands

Command	Command Name	Function
VS x.x.x.x	Version	Queries software header record (16 bytes) of unit with IP address x.x.x.x.
GC x.x.x.x	Get Configuration	Gets configuration of unit with IP address x.x.x.x as hex records (120 bytes).
SC x.x.x.x	Send Configuration	Sets configuration of unit with IP address x.x.x.x from hex records.
PI x.x.x.x	Ping	Pings unit with IP address x.x.x.x to check device status.
AT	ARP Table	Shows the unit's ARP table entries.
TT	TCP Connection Table	Shows all incoming and outgoing TCP connections.
NC	Network Connection	Shows the unit's IP address, gateway, subnet mask, and DNS server.
RS	Reset	Resets the unit's power.
QU	Quit	Exits diagnostics mode.
G0, G1, ..., Ge, Gf	Get configuration from memory page	Gets a memory page of configuration information from the device.
S0, S1, ..., Se, Sf	Set configuration to memory page	Sets a memory page of configuration information on the device.
GM	Get MAC address	Shows the unit's 6-byte MAC address.
SS	Set Security record	Sets the Security record without the encryption key and length parameters. The entire record must still be written, but the encryption-specific bytes do not need to be provided (they can be null since they are not overwritten).
SA	Scan	Initiates a wireless scan if the wireless interface is enabled. Reports any stations found, including BSSID, SSID, and RSSI. If SA is followed by a string, the string is used to filter SSIDs before reporting. If the BSS does not broadcast its SSID, only the BSSID and RSSI are returned.
NS	Network Status	Reports the network interfaces' statuses. Includes potentially negotiated parameters like speed/duplex for Ethernet or BSSID, encryption, authentication for wireless interfaces.
co	Set IP address, hostbits, gateway, and DNS server IP	<p>Example:</p> <pre>co 192.168.0.10 8 192.168.0.1 10001 192.168.1.10</pre> <p>with 192.168.0.10 = IP address of the xPico 8 = number of hostbits 192.168.0.1 = gateway IP address 10001 = port number of the xPico Channel 1 192.168.1.10 = IP address of the DNS Server The xPico stores the setup and performs a reset. It sends an X before the reset if the command was OK.</p>

Note: Entering any of the commands listed above generates one of the following command response codes:

Table 11-2. Command Response Codes

Response	Meaning
0>	OK; no error
1>	No answer from remote device
2>	Cannot reach remote device or no answer
8>	Wrong parameter(s)
9>	Invalid command

12. Troubleshooting

This chapter discusses how you can diagnose and fix errors quickly without having to contact a dealer or Lantronix. It helps to connect a terminal to the serial port while diagnosing an error to view summary messages that may display. When troubleshooting, always ensure that the physical connections (power cable, network cable, and serial cable) are secure.

Note: Some unexplained errors might be caused by duplicate IP addresses on the network. Make sure that your unit's IP address is unique.

When troubleshooting the following problems, make sure that the xPico is powered up. Confirm that you are using a good network connection.

Problems and Error Messages

Problem/Message	Reason	Solution
When you issue the ARP -S command in Windows, the "ARP entry addition failed: 5" message displays.	Your currently logged-in user does not have the correct rights to use this command on this PC.	Have someone from your IT department log you in with sufficient rights.
When you attempt to assign an IP address to the unit by the ARP method, the "Press Enter to go into Setup Mode" error (described below) message displays. Now when you Telnet to the device server, the connection fails.	When you Telnet to port 1 on the device server, you are only assigning a temporary IP address. When you Telnet into port 9999 and do not press Enter quickly, the device server reboots, causing it to lose the IP address.	Telnet back to Port 1. Wait for it to fail, then Telnet to port 9999 again. Make sure you press Enter quickly.
When you Telnet to port 9999, the "Press Enter to go into Setup Mode" message displays. However, nothing happens when you press Enter , or your connection is closed.	You did not press Enter quickly enough. You only have 5 seconds to press Enter before the connection is closed.	Telnet to port 9999 again, but press Enter as soon as you see the "Press Enter to go into Setup Mode" message.

Problem/Message	Reason	Solution
<p>When you Telnet to port 1 to assign an IP address to the device server, the Telnet window does not respond for a long time.</p>	<p>You may have entered the Ethernet address incorrectly with the ARP command.</p>	<p>Confirm that the Ethernet address that you entered with the ARP command is correct. The Ethernet address may only include numbers 0-9 and letters A-F. In Windows and usually in Unix, the segments of the Ethernet address are separated by dashes. In some forms of Unix, the Ethernet address is segmented with colons.</p>
	<p>The IP address you are trying to assign is not on your logical subnet.</p>	<p>Confirm that your PC has an IP address and that it is in the same logical subnet that you are trying to assign to the device server.</p>
	<p>The device server may not be plugged into the network properly.</p>	<p>Make sure that the Link LED is lit. If the Link LED is not lit, then the device server is not properly plugged into the network.</p>
<p>When you try to assign an IP with DeviceInstaller, you get the following :</p> <p>"No response from device! Verify the IP, Hardware Address and Network Class. Please try again."</p>	<p>The cause is most likely one of the following:</p> <p>The hardware address you specified is incorrect.</p> <p>The IP address you are trying to assign is not a valid IP for your logical subnet.</p> <p>You did not choose the correct subnet mask.</p>	<p>Double-check the parameters that you specified.</p> <p>Note: <i>You cannot assign an IP address to a device server through a router.</i></p>
<p>The device server is not communicating with the serial device to which it is attached.</p>	<p>The most likely reason is the wrong serial settings were chosen.</p>	<p>The serial settings for the serial device and the device server must match. The default serial settings for the device server are RS-232, 9600 baud, 8 character bits, no parity, 1 stop bit, no flow control.</p>
<p>When you try to enter the setup mode on the device server using the serial port, you get no response.</p>	<p>The issue is most likely something covered in the previous problem, or possibly, you have Caps Lock on.</p>	<p>Double-check everything in the problem above. Confirm that Caps Lock is not on.</p>

Problem/Message	Reason	Solution
<p>You can ping the device server, but not Telnet to the device server on port 9999.</p>	<p>There may be an IP address conflict on your network</p> <p>You are not Telnetting to port 9999.</p> <p>The Telnet configuration port (9999) is disabled within the device server security settings.</p>	<p>Turn the device server off and then issue the following commands at the DOS prompt of your computer:</p> <p>ARP -D X.X.X.X (X.X.X.X is the IP of the device server).</p> <p>PING X.X.X.X (X.X.X.X is the IP of the device server). If you get a response, then there is a duplicate IP address on the network. If you do not get a response, use the serial port to verify that Telnet is not disabled.</p>
<p>The device server appears to be set up correctly, but you are not communicating with your device attached to the device server across the network.</p>	<p>If you are sure that the serial port setting is correct, then you may not be connecting to the correct socket of the device server.</p> <p>Another possibility is that the device server is not set up correctly to make a good socket connection to the network.</p>	<p>You can check to see whether there is a socket connection to or from the device server by checking the state of CPx, if one of the CPs has been configured for Serial Channel Status LED functionality.</p> <p>If the state of CPx is blinking consistently, then there is a good socket connection.</p> <p>If the state of CPx is low, use the Connect Mode option C0 for making a connection to the device server from the network. Use Connect Mode option C1 or C5 for a connection to the network from the device server. See the full list of Connect Mode options in Connect Mode</p>
<p>When connecting to the Web-Manager within the device server, the "No Connection With The Device Server" message displays.</p>	<p>Your computer is not able to connect to port 30718 (77FEh) on the device server.</p>	<p>Make sure that port 30718 (77FEh) is not blocked with any router that you are using on the network. Also, make sure that port 77FEh is not disabled within the Security settings of the device server.</p>

Technical Support

If you are experiencing an error that is not described in this chapter, or if you are unable to fix the error, you have the following options:

Technical Support US

Check our online knowledge base or send a question to Technical Support at <http://www.lantronix.com/support>.

Phone: (800) 422-7044 (US Only)
(949) 453-7198

Technical Support Europe, Middle East, and Africa

Phone: +33 (0)1 39 30 4172
+49 (0) 180 500 13 53 (Germany Only)

Email: eu_techsupp@lantronix.com or eu_support@lantronix.com

Firmware downloads, FAQs, and the most up-to-date documentation are available at www.lantronix.com/support.

When you report a problem, please provide the following information:

- ◆ Your name, and your company name, address, and phone number
- ◆ Lantronix model number
- ◆ Lantronix MAC number
- ◆ Software version (on the first screen shown when you Telnet to port 9999)
- ◆ Description of the problem
- ◆ Status of the unit when the problem occurred (please try to include information on user and network activity at the time of the problem).

A: Binary to Hexadecimal Conversions

Many of the unit's configuration procedures require assembling a series of options (represented as bits) into a complete command (represented as a byte). Convert the resulting binary value to a hexadecimal representation.

Converting Binary to Hexadecimal

Following are two simple ways to convert binary numbers to hexadecimal.

Conversion Table

Hexadecimal digits have values ranging from 0 to F, which are represented as 0-9, A (for 10), B (for 11), etc. To convert a binary value (for example, 0100 1100) to a hexadecimal representation, the upper and lower four bits are treated separately, resulting in a two-digit hexadecimal number (in this case, 4C). Use the following table to convert values from binary to hexadecimal.

Decimal	Binary	Hex
0	0000	0
1	0001	1
2	0010	2
3	0011	3
4	0100	4
5	0101	5
6	0110	6
7	0111	7
8	1000	8
9	1001	9
10	1010	A
11	1011	B
12	1100	C
13	1101	D
14	1110	E
15	1111	F

Scientific Calculator

Another simple way to convert binary to hexadecimal is to use a scientific calculator, such as the one available on Windows' operating systems. For example:

1. On the Windows' Start menu, click **Programs**→**Accessories**→**Calculator**.
2. On the **View** menu, select **Scientific**. The scientific calculator displays.
3. Select **Bin** (Binary), and type the number to convert.

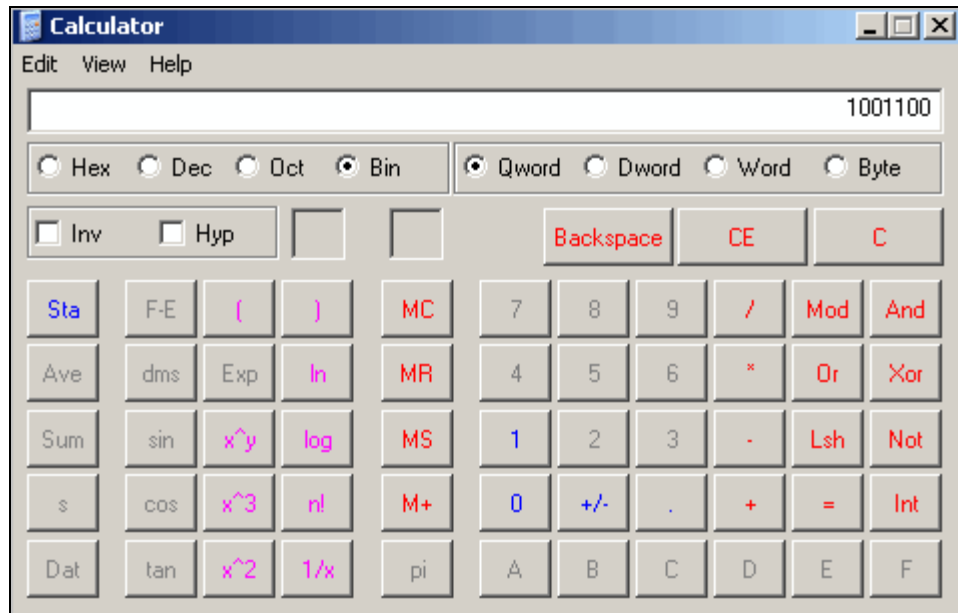

4. Click Hex. The hexadecimal value displays.

B: Compliance

RoHS Notice

All Lantronix products in the following families are China RoHS-compliant and free of the following hazardous substances and elements:

- Lead (Pb)
- Mercury (Hg)
- Polybrominated biphenyls (PBB)
- Cadmium (Cd)
- Hexavalent Chromium (Cr (VI))
- Polybrominated diphenyl ethers (PBDE)

Product Family Name	Toxic or hazardous Substances and Elements					
	Lead (Pb)	Mercury (Hg)	Cadmium (Cd)	Hexavalent Chromium (Cr (VI))	Polybrominated biphenyls (PBB)	Polybrominated diphenyl ethers (PBDE)
UDS1100 and 2100	0	0	0	0	0	0
EDS	0	0	0	0	0	0
MSS100	0	0	0	0	0	0
IntelliBox	0	0	0	0	0	0
XPress DR & XPress-DR+	0	0	0	0	0	0
SecureBox 1101 & 2101	0	0	0	0	0	0
WiBox	0	0	0	0	0	0
UBox	0	0	0	0	0	0
MatchPort	0	0	0	0	0	0
SLC	0	0	0	0	0	0
XPort	0	0	0	0	0	0
WiPort	0	0	0	0	0	0
SLB	0	0	0	0	0	0
SLP	0	0	0	0	0	0
SCS	0	0	0	0	0	0
SLS	0	0	0	0	0	0
DSC	0	0	0	0	0	0
PremierWave	0	0	0	0	0	0
Micro125	0	0	0	0	0	0
xPico	0	0	0	0	0	0
xPrintServer	0	0	0	0	0	0

O: toxic or hazardous substance contained in all of the homogeneous materials for this part is below the limit requirement in SJ/T11363-2006.

X: toxic or hazardous substance contained in at least one of the homogeneous materials used for this part is above the limit requirement in SJ/T11363-2006.