

Super Mini Full SiC DIIPM™ Series for high efficiency

Mitsubishi Electric has developed New Super Mini Full SiC DIIPM (hereinafter called Full SiC DIP) for Consumer Goods Applications. Full SiC DIP is an ultra-small compact transfer molded intelligent power module integrating SiC MOSFET chip which is the next generation high efficiency power chips. Power chips, drive and protection circuits are integrated in the module with transfer molding resin.

Full SiC DIP can improve inverter efficiency drastically by embedding SiC MOSFET chips, and additionally the Full SiC DIP package is 100% compatible with conventional Super Mini DIIPM Ver.6 series. This compatibility enables to utilize the existing conventional inverter boards easily and to expand the lineup of installed systems.

Features

- ❑ Integrated newly developed SiC MOSFET for improving efficiency
- ❑ NO requirement of negative bias by mounting MOSFET with high threshold voltage VGsth.
- ❑ Single DC 18V power supply drive with bootstrapping scheme.
- ❑ Safety operating SiC MOSFET by protection functions.
- ❑ Easy to replace from conventional Ver.6 due to pin and function compatibility.

The difference between conventional Ver.6 and Full SiC DIP

Items	Super Mini DIIPM Ver.6	Super Mini Full SiC DIIPM
P-side control supply voltage VDB	Typ. 15V (13~18.5V)	Typ. 18V (15~22V)
N-side control supply voltage VD	Typ. 15V (13~16.5V)	Typ. 18V (17~19V)
Built-in bootstrap diodes	Built-in with current limiting resistor	←
Temperature protection	OT or VOT	VOT
N-side IGBT emitter terminal	Open	←
Terminal shape	Long	←

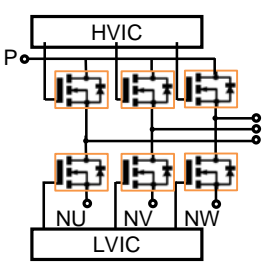
Circuit	Circuit Diagram	Package Size	Product Name	Application
6in1		24 mm X 38 mm	PSF15S92F6 (15A / 600V) PSF25S92F6 (25A / 600V)	AC 100-240Vrms class low power motor control



Home Appliance



Industrial

for a greener tomorrow



Functions

- ▣ For P-side MOSFETs:
 - Drive circuit, high voltage level shift circuit;
 - Control supply under voltage lockout circuit (without fault signal output)
 - Built-in bootstrap diode with current resistor
- ▣ For N-side MOSFETs:
 - Drive circuit;
 - Short circuit protection circuit (by inserting external shunt resistor into main current path)
 - Control supply under voltage lockout circuit (with fault signal output)
 - Outputting LVIC temperature by analog signal
- ▣ Fault Signal Output
 - Corresponding to N-side MOSFET SC and N-side UV
- ▣ MOSFET Drive Supply
 - Single DC18V power supply (in case of using bootstrap method)
- ▣ Control Input Interface
 - Schmitt-triggered 3V, 5V input compatible, high active logic
- ▣ UL recognized
 - UL 1557 File E323585

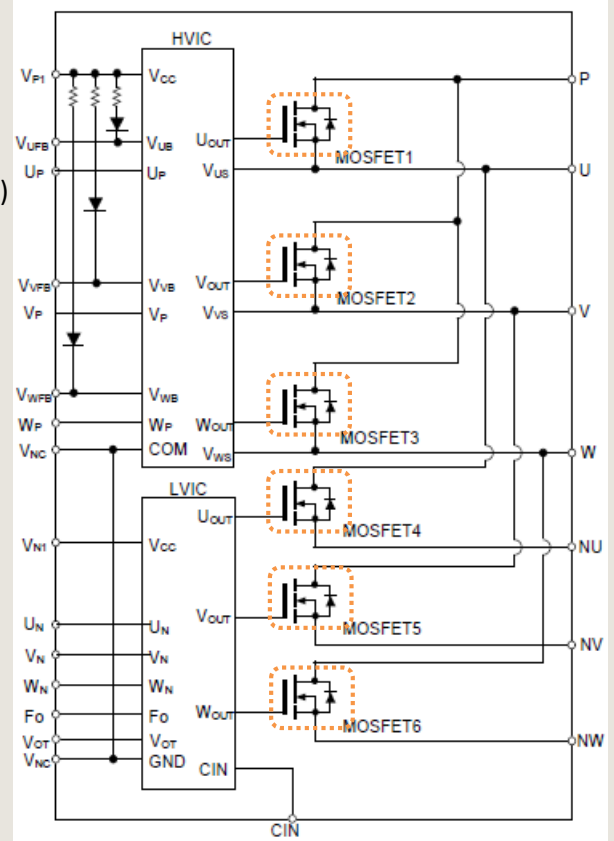

Increased Performance

Due the reduction in the switching losses with the Full SiC technology, the performance is significantly increased in comparison with the conventional Si technology.

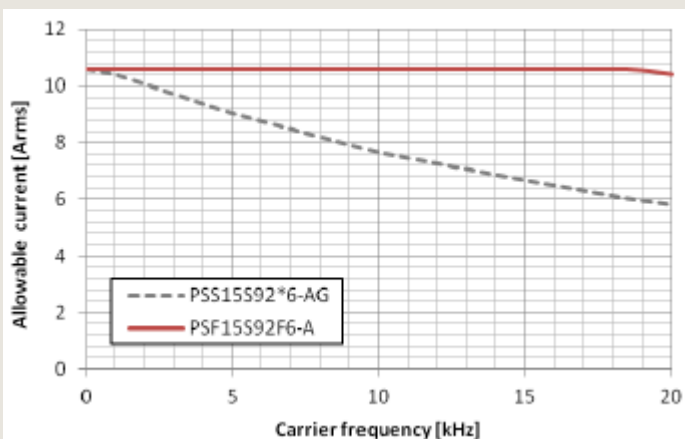

[Condition]

Simulation model: 3 phase PWM

VCC=VDD=300V, M=1, P.F=0.8, fo=60Hz, Tj=Tch=125°C, Tc=100°C

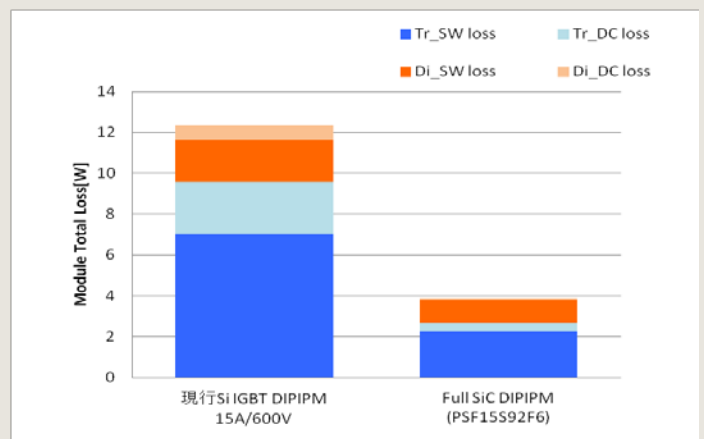

[Condition]

Simulation model: 3 phase PWM

VCC=VDD=300V, M=0.8, PF=0.95, Io=1.5rms, fc=15kHz, fo=60Hz, Tj=Tch=125°C

Mitsubishi Electric Europe B.V. (European Headquarters)

– Semiconductor European Business Group –

Mitsubishi-Electric-Platz 1 / D-40882 Ratingen

Phone +49 (0) 2102 486 0

Fax +49 (0) 2102 486 7220

www.MitsubishiElectric.com

www.mitsubishichips.eu

Ihr Vertriebspartner:

HY-LINE
POWER COMPONENTS

Inselkammerstraße 10
D-82008 Unterhaching
Tel: +49 (0)89 614 503 10
Fax: +49 (0)89 614 503 20
E-Mail: power@hy-line.de
URL: www.hy-line.de

for a greener tomorrow

