

EM3260

Embedded USB3.0 Flash Controller

The EM3260 is the USB3.0/USB2.0 high performance Flash drive controller focusing on embedded/industrial application (eUSB) usage. It combines high compatibility and high performance to support dual -channel SLC and MLC NAND Flash memory in a single chip. The EM3260 complies with USB3.0 power specifications for bus-powered devices. The EM3260 supports high capacity (up to 16 Flash devices) with small form factor.

The EM3260 delivers high data transfer rate, and ensures data accuracy and reliability with the powerful ECC engine. The EM3260 is available in 88 pin QFN package.

Applications

- USB Flash Drive
- Embedded USB Flash Drive (eUSB)
- Embedded/Industrial Application
 - Telecommunication
 - Set-top-box
 - IPC/SBC
 - Multifunction Printer
 - DRAM caching

Key Features

- Complete compliant with USB (Universal Serial Bus) Specification Rev. 3.0
- Complies with USB Mass Storage Class Specification Rev. 1.0
- Supports LPM
- Supports high-speed Toggle NAND and ONFI2.x NAND flash interface
- Supports 3.3V/1.8V VCCQ SLC and MLC up to 16 NAND flash devices
- GPIO available for vendor specific feature
- Field firmware update capability
- Firmware customization capability for specific application requirement

Reliability

- Industrial approved FTL to protect data in an ungraceful power lost event.
- DataRefresh and EarlyRetirement features to prevent data corruption due to uncorrectable ECC
- Proprietary algorithm for read/retry to retrieve correct data due to platform instability
- Global Wear Leveling to ensure all NAND flash blocks are evenly written to extend the device life.
- HealthMonitoring vendor commands to allow monitoring the health status
- Extended overprovisioning capability enables longer life expectancy
- Software "Write Protection" feature enables data write protect at any instant.

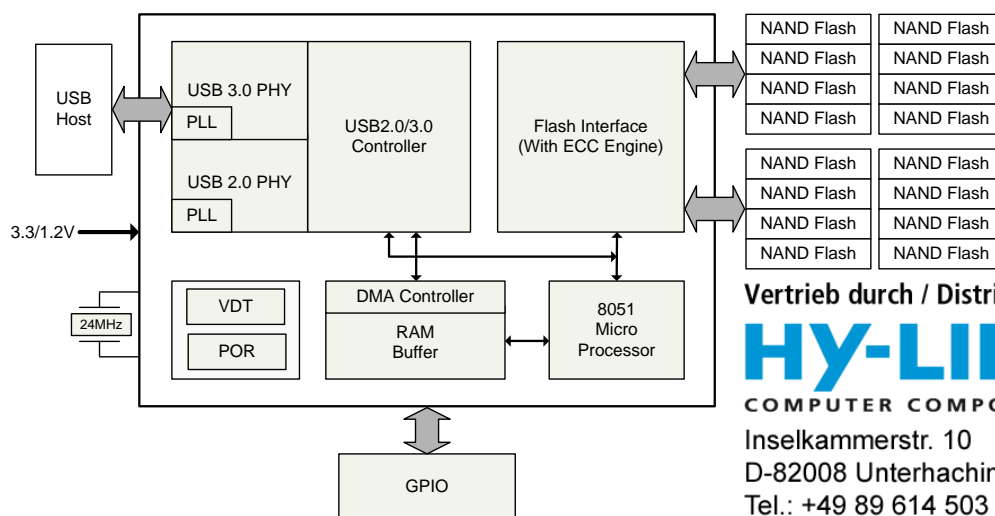

Vertrieb durch / Distribution by
HY-LINE[®]
 COMPUTER COMPONENTS
 Inselkammerstr. 10
 D-82008 Unterhaching
 Tel.: +49 89 614 503 40
 www.hy-line.de